



地址：郑州荥阳汜水工业区 (450141)
Add: YUMING INDUSTRIAL PARK, XINGYANG CITY, ZHENGZHOU HENAN CHINA
Tel: +8618838296432
Fax: 0371-64892666
E-mail: yuming@ym-valves.com
sales@ym-valves.com

WEB: www.yuming-valves.com
www.ym-valves.com

FOR MORE INFORMATION ABOUT OUR TECHNOLOGY,
PLEASE VISIT HERE www.yuming-valves.com



宇明阀门集团
YUMING VALVE GROUP

Harbor the world a Better Tomorrow

— Warmly celebrate the 50th anniversary of Yuming valve group —

中国驰名商标
China Well-known Trademark



企业简介

Company Profile

宇明阀门集团有限公司位于“中国阀门之乡”荥阳，北临黄河，毗邻S314省道，连霍高速、陇海铁路，交通便利，物流发达。公司始建于1972年，工业园区占地面积82000平方米。现有员工500余人，各类专业技术人员80余人，注册资金1亿元。已成为集研发、制造、销售于一体的专业阀门制造商。

2021年，宇明阀门出口营业额突破2000万美元；2022年，宇明阀门出口营业额突破2500万美元，并试图在未来做的更好。在2021年新增两条生产线，主要生产大型工程类阀门(DN4000以下)；并在2021年底投资郑州一阀流体科技有限公司，拥有生产设备600多台，其中机加工、试验机、测量设备300多台，操作人员约400多人，我们拥有多年的阀门制造经验，并且拥有最专业的团队。我们想强调的是，在宇明的研发部门有6名高级工程师和12名相关的主要工程师帮助CAD绘图和技术支持，另外4名专家在QC部门。

除了优秀的生产团队，宇明阀门还拥有全面的销售管理，与全球客户打交道。95%的营业额来自出口俄罗斯、阿根廷、菲律宾、越南、印度尼西亚、哥伦比亚秘鲁、智利、瑞典、挪威、比利时、法国、德国、罗马尼亚、意大利、西班牙、土耳其、以色列、伊朗、埃及、南非、澳大利亚、马来西亚、泰国、新加坡、美国、香港、台湾和韩国，与中外朋友合作共赢，建立了牢固的合作关系，同时更结下了深厚的情谊，为宇明阀门的发展注入了持久的活力。

选择“宇明”，选择“信任”。

Yuming Valve Group Co., Ltd. is located in Xingyang, the "Hometown of Valves in China", facing the Yellow River to the north, adjacent to S314 Provincial Highway, Lianhuo Expressway and Longhai Railway, with convenient transportation and developed logistics. The company was founded in 1972, and the industrial park covers an area of 82,000 square meters. There are more than 500 employees, more than 80 professional and technical personnel of various types, and a registered capital of 100 million yuan. It has become a professional valve manufacturer integrating R&D, manufacturing and sales.

2021, Yuming valve export turnover exceeded 20 million US dollars. In 2022, Yuming valve export turnover exceed 25 million US dollars, and is trying to do more in the future. In 2021, two new production lines has added, mainly producing bigger size(up to DN4000) engineering valves; and at the end of 2021, we invested in Zhengzhou Yiva Fluid Technology Co., Ltd., and we have more than 600 production facilities, including more than 300 machining, testing machines, and measuring equipment. about 400 operators, we have many years of valve manufacturing experience, and have the most professional team. We would like to emphasize that there are 6 senior engineers and 12 related main engineers in Yuming's R&D department to help with CAD drawing and technical support, and the other 4 experts are in the QC department.

In addition to an excellent production team, Yuming Valve also has a comprehensive sales management to deal with global customers. And 95% of the turnover comes from exports to Russia, Argentina, the Philippines, Vietnam, Indonesia, Colombia, Peru, Chile, Sweden, Norway, Belgium, France, Germany, Romania, Italy, Spain, Turkey, Israel, Iran, Egypt, South Africa, Australia, Malaysia, Thailand, Singapore, the United States, Hong Kong, Taiwan and South Korea, and win-win cooperation with Chinese and foreign friends, established a deep cooperative relationship, and at the same time forged a stronger friendship, which injected lasting vitality into the development of Yuming.

Select "Yuming", select "Trust"

YUMING VALVE GROUP

Expert in Industry Fluid System Control

企业资质

Enterprise Qualification

企业获得的资质和荣誉，是对宇明集团过去取得成绩的肯定，也是对宇明集团创造明日辉煌的鼓舞和鞭策！向新的台阶迈进，是宇明人顽强拼搏，永远追求的信念！

Qualifications and honors obtained by the enterprise, It is an affirmation of Yuming Group's achievements in the past, It is also an encouragement and spur to Yuming Group to create a brilliant tomorrow! to a new level,



YUMING VALVE GROUP

Expert in Industry Fluid
System Control

铸件生产 Casting Production

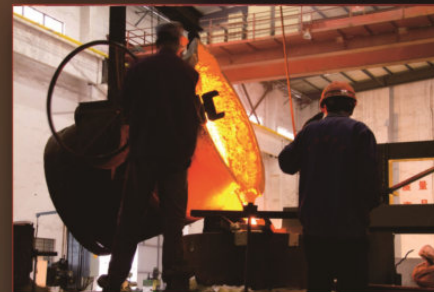

YUMING VALVE GROUP

Expert in Industry Fluid
System Control

生产装备 Production equipment

拥有铸造、加工、焊接、热处理等先进的加工设备和专业化的生产车间，不断完善产品加工工艺，严格控制产品制造的每一道工序、每一个环节，精益求精，确保宇明阀门的优良品质。

It has advanced processing equipment such as casting, machining, welding, heat treatment, and specialized production workshops, constantly improves product processing technology, strictly controls every process and every link of product manufacturing, and strives for excellence to ensure the excellent quality of Yuming valves.



YUMING VALVE GROUP

Expert in Industry Fluid
System Control

检测中心 Test Center



• 冲击试验机
Impact testing machine

为了提供高品质产品，公司配置了先进的检测设备以及完善的检测手段，建立了一支严格要求的品质管理队伍，实现了从原材料检测，生产过程检测，产品及应用全过程的质量控制。

In order to improve the quality of products, The company is equipped with advanced testing equipment and perfect testing methods, Established a strict quality management team, Realized from the detection of raw materials, production process testing, Quality control of the whole process of products and applications.

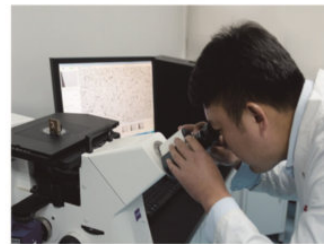

• 金相分析仪
Metallographic Analyzer

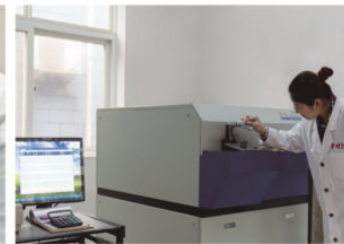

• 直读光谱仪
Direct Reading Spectrometer



• 试样制备机
Sample preparation machine

YUMING VALVE GROUP

 Expert Industry Fluid
 System Control

铸铁阀门

Cast iron valves

Small flow resistance. The media channel inside the valve body is straight, the media into a straight line flow, small flow resistance.

It saves effort when opening and closing. Is compared with the globe valve, because whether open or closed, the direction of movement of the gate is perpendicular to the direction of media flow.

Large height, long opening and closing time. The opening and closing stroke of the gate is larger, and the lowering is carried out by the screw.

The shape is simple, the structure length is short, the manufacturing process is good, and the scope of application is wide.

Compact structure, good rigidity of the valve, smooth passage, small flow resistance, sealing surface of stainless steel and hard alloy, long service life, reliable sealing, light and flexible operation.



Cast iron series

Resilient Seated Gate Valve

03-07	DIN3202 F4/F5 Resilient Seated Gate Valve
08-08	AS 2638.2 Non-Rising Stem Resilient Seated Gate Valve
09-11	BS 5163 Resilient Seated Gate Valve
12-12	Socket Ends Non-rising Resilient Seated Gate Valves
13-14	AWWA C509/C515 Resilient Seated Gate Valve

Metal Seated Gate Valve

17-23	DIN 3352 F4/F5 Metal Seated Gate Valve
24-24	JIS Rising Stem Solid Wedge Gate Valve
25-28	ANSI 125/150 Metal Seated Gate Valve
29-32	BS 5150/5163 Metal Seated Gate Valve
33-34	BS3464 Metal Seated Gate Valve

Cast Iron Globe Valve & Check Valve

37-38	DIN3356 Globe Valve
39-39	ANSI / MSS SP-85 Globe Valve
40-40	BS5152 Globe Valve
42-42	DIN3202 F6 Swing Check Valve
43-43	MSS SP-71/ ANSI Swing Check Valve
44-44	BS5153 Swing Check Valve
45-46	Ball Type Check Valve (Threaded Ends And Flanged Ends)
47-47	DIN Lift Check Valve
48-48	DIN Rubber Flapper Check Valve

Cast Iron Strainer

51-51	DIN/BS Y Strainer
52-52	ANSI Y Strainer
53-53	AS Y Strainer
54-54	Grooved End Y-Strainer
54-54	Simplex Basket Strainers

Cast Iron Ball Valve & Rubber Expansion Joint

55-56	DIN Cast Iron Ball Valve
57-57	MSS/ANSI Cast Iron Ball Valve
58-60	Rubber Expansion Joint

RESILIENT SEATED GATE VALVE

◆ Normal Features:

- Ductile Iron Body & Bonnet with high strength and impact resistance.
- Rubber Encapsulated DI wedge to ensure drop tight sealing.
- Rubber bonnet gasket for longevity and protection of bonnet bolts.
- Stainless Steel Stem with high strength and corrosion resistance.
- Back sealing facility to allow for replacement of seals under full operating pressure.
- Straight through full bore to avoid debris traps.
- Isolated fasteners for corrosion protection.
- Wiper ring to prevent impurities from entering the stem sealing system.
- Anti friction thrust washer for low operating torques. Integral cast in foot for safe and easy storage.
- Full diameter waterway
Hand wheel, square cap operation.



◆ Application :

Resilient Seated Gate Valves are suitable for use in drinking water and waste water, which can be installed under or above ground. Rising stem gate valves are normally used in fire service application and socket end resilient gate valves are normally used in PVC pipelines.

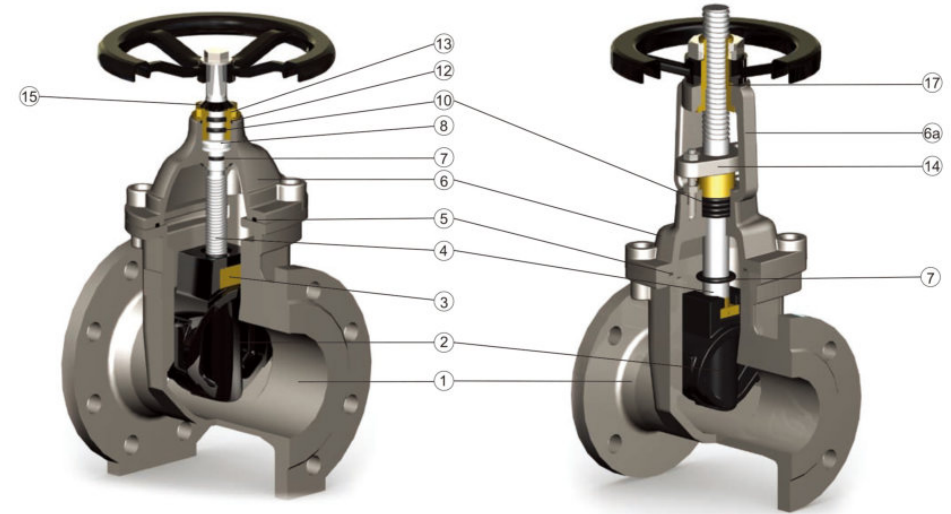

Item No.	Part Name	Specification	Material
1	Body	Ductile Iron	GGG50(EN-GJS-500-7) ASTM A536 65-45-12
2	Wedge	Ductile Iron +EPDM	GGG50+EPDM ASTM A536+EDPM
		Ductile Iron +NBR	GGG50+NBR ASTM A536+NBR
3	Wedge Nut	Brass	COPPER ALLOY EN 12165 ASTM B16 C36000
		Bronze	EN 1982 CC491K ASTM B62 C83600
4	Stem	Stainless Steel	X20 Cr13 SS AISI 420
		Brass	CuZn39Pb3 ASTM B16 C36000
5	Bonnet Gasket	EPDM/NBR	ASTM D2000
6	Bonnet	Ductile Iron	GGG50(EN-GJS-500-7) ASTM A536 65-45-12
6a	Yoke	Ductile Iron	GGG50(EN-GJS-500-7) ASTM A536 65-45-12
7	O Ring Back Sealing	EPDM/NBR	EPDM/NBR EPDM/NBR
8	Thrust Washer	PTFE /Nylon	PTFE /Nylon PTFE /Nylon
9	Stem Collar	Stainless Steel	
		Brass	
10	O-Ring	EPDM/NBR	ASTM D2000
11. 12	O-Ring	EPDM/NBR	ASTM D2000
13	Stuffing Nut	Brass	COPPER ALLOY EN 12165 ASTM B16 C36000
14	Gland Flange	Ductile Iron	GGG50(EN-GJS-500-7) ASTM A536 65-45-12
15	Dust Guard	EPDM/NBR	ASTM D2000
16	HandWheel	Ductile Iron	GGG50(EN-GJS-500-7) ASTM A536 65-45-12
17	Stem Nut	Brass	COPPER ALLOY EN 12165 ASTM B16 C36000



DIN3352 F4 Non-Rising Stem Resilient Seated Gate Valve Type B

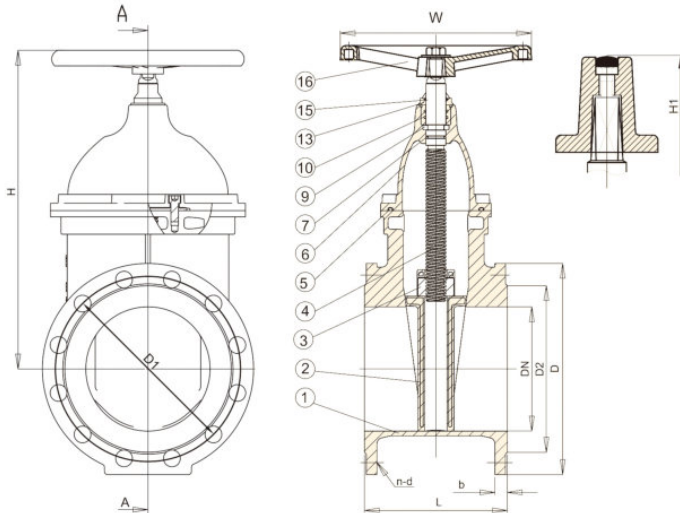

Features

- Replaceable O-ring
- Low torque operation
- Rubber encapsulated wedge
- Clockwise closing direction
- Fusion bonded epoxy coated inside and outside
- Product color: Blue RAL 5017
- Maximum temperature 80°C

Technical Specification

- Design: DIN 3352
- Face to Face : DIN3202 F4
- Flanges: EN 1092-2 PN16
- Hydraulic test to ISO 5208
Seat Test Pressure: 17.6 bar
Shell Test Pressure: 24 bar
Operating torque test

Optional Extras:

- Stem Cap
- Position Indicator
- Extension Spindle / T Key

▲ MATERIAL SPECIFICATION

Item	Part Name	Material	Item	Part Name	Material
1	Body	GGG50	5	Bonnet Gasket	EPDM/NBR
2	Wedge	GGG50+EPDM	6	Bonnet	GGG50
		GGG50+NBR	7	Back Sealing O Ring	EPDM/NBR
3	Wedge Nut	Brass	10	O-Ring	EPDM/NBR
4	Stem	AISI 420	13	Stuffing Nut	Brass

▲ DIMENSIONS(mm)

Size	L	D	D1	D2	b	n-d	H	H1	W	W.T(kg)
DN40	140	150	110	84	19	4-19	240	310	160	9
DN50	150	165	125	99	19	4-19	250	320	160	11
DN60	170	175	135	108	19	4-19	265	335	180	14
DN65	170	185	145	118	19	4-19	265	335	180	14
DN80	180	200	160	132	19	8-19	300	370	200	17
DN100	190	220	180	156	19	8-19	350	420	200	21
DN125	200	250	210	184	19	8-19	410	480	220	29
DN150	210	285	240	211	19	8-23	450	520	250	38
DN200	230	340	295	266	20	12-23	550	620	280	58
DN250	250	405	355	319	22	12-28	650	720	320	90
DN300	270	460	410	370	24.5	12-28	710	780	350	120

DIN3352 F5 Non-Rising Stem Resilient Seated Gate Valve Type B

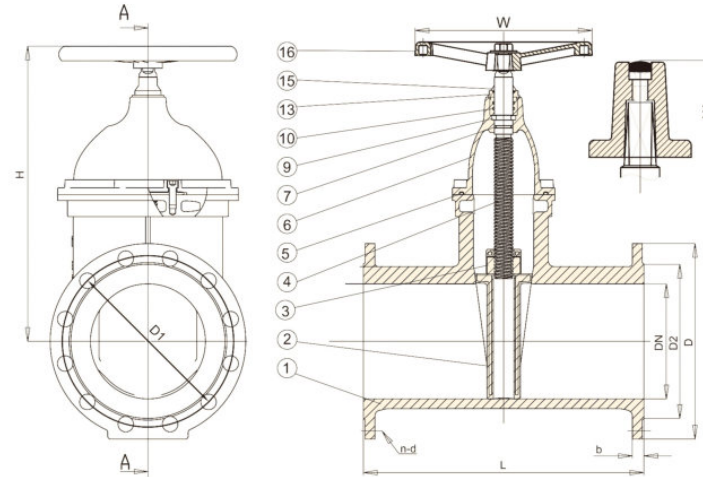

Features

- Replaceable O-ring
- Low torque operation
- Rubber encapsulated wedge
- Clockwise closing direction
- Fusion bonded epoxy coated inside and outside
- Product color: Blue RAL 5017
- Maximum temperature 80°C

Technical Specification

- Design: DIN 3352
- Face to Face : DIN3202 F5
- Flanges: EN 1092-2 PN16
- Hydraulic test to ISO 5208
Seat Test Pressure: 17.6 bar
Shell Test Pressure: 24 bar
Operating torque test

Optional Extras:

- Stem Cap
- Position Indicator
- Extension Spindle / T Key

▲ MATERIAL SPECIFICATION

Item	Part Name	Material	Item	Part Name	Material
1	Body	GGG50	5	Bonnet Gasket	EPDM/NBR
2	Wedge	GGG50+EPDM	6	Bonnet	GGG50
		GGG50+NBR	7	Back Sealing O Ring	EPDM/NBR
3	Wedge Nut	Brass	10	O-Ring	EPDM/NBR
4	Stem	AISI 420	13	Stuffing Nut	Brass

▲ DIMENSIONS(mm)

Size	L	D	D1	D2	b	n-d	H	H1	W	W.T(kg)
DN40	240	150	110	84	19	4-19	240	310	160	10.5
DN50	250	165	125	99	19	4-19	250	320	160	12
DN60	270	175	135	108	19	4-19	265	335	180	15.5
DN65	270	185	145	118	19	4-19	265	335	180	15.5
DN80	280	200	160	132	19	8-19	300	370	200	19.5
DN100	300	220	180	156	19	8-19	350	420	200	25.5
DN125	325	250	210	184	19	8-19	410	480	220	34
DN150	350	285	240	211	19	8-23	450	520	250	45
DN200	400	340	295	266	20	12-23	550	620	280	69
DN250	450	405	355	319	22	12-28	650	720	320	106
DN300	500	460	410	370	24.5	12-28	710	780	350	148

DIN3202 F4/F5 Non-Rising Stem Resilient Seated Gate Valve Type C

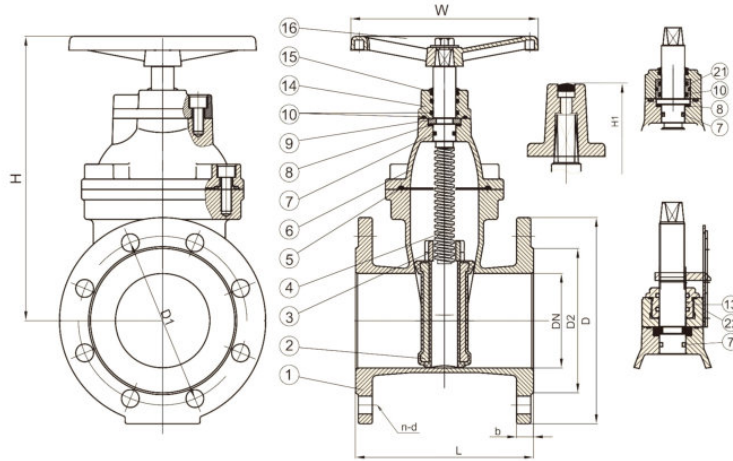

Features

- Replaceable O-ring
- Low torque operation
- Rubber encapsulated wedge
- Clockwise closing direction
- Fusion bonded epoxy coated inside and outside
- Product color: Blue RAL 5017
- Maximum temperature 80°C

Technical Specification

- Design: DIN 3352
- Face to Face : DIN3202 F4/F5
- Flanges: EN 1092-2 PN16
- Hydraulic test to ISO 5208
Seat Test Pressure: 17.6 bar
Shell Test Pressure: 24 bar
Operating torque test

Optional Extras:

- Stem Cap
- Position Indicator
- ISO Top Flange
- Extension Spindle / T Key

▲ MATERIAL SPECIFICATION

Item	Part Name	Material	Item	Part Name	Material
1	Body	GGG50	11	O-Ring	EPDM/NBR
2	Wedge	DI+EPDM/DI+NBR	13	Stuffing Nut	Brass
3	Wedge Nut	Brass	14	Gland Flange	GGG50
4	Stem	AISI 420	21	Stuffing Bearing	Brass
10	O-Ring	EPDM/NBR	22	Position indicator	Stainless Steel

▲ DIMENSIONS(mm)

Size	L		D	D1	D2	b	n-d	H	H1	W	W.T(kg)	
	F4	F5									F4	F5
DN40	140	240	150	110	84	19	4-19	240	310	160	9	10.5
DN50	150	250	165	125	99	19	4-19	250	320	160	11	12
DN65	170	270	185	145	118	19	4-19	265	335	180	14	15.5
DN80	180	280	200	160	132	19	8-19	300	370	200	17	19.5
DN100	190	300	220	180	156	19	8-19	350	420	200	21	25.5
DN125	200	325	250	210	184	19	8-19	410	480	220	29	34
DN150	210	350	285	240	211	19	8-23	450	520	250	38	45
DN200	230	400	340	295	266	20	12-23	550	620	280	58	69
DN250	250	450	405	355	319	22	12-28	650	720	320	90	106
DN300	270	500	460	410	370	24.5	12-28	710	780	350	120	148

DIN3202 F4/F5 Big Size Gate Resilient Seated Valve Type C

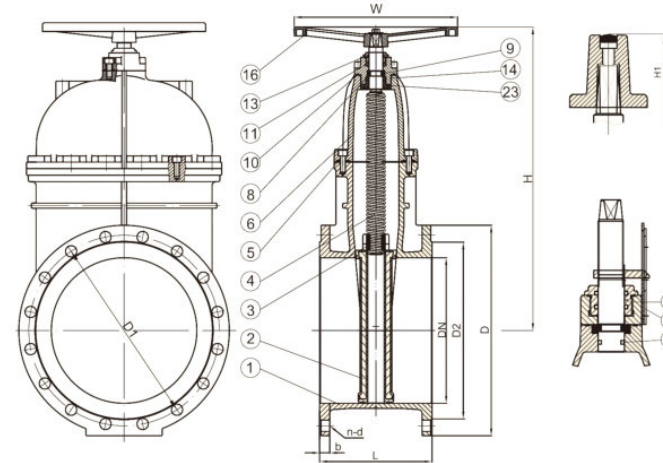

Features

- Replaceable O-ring
- Low torque operation
- Rubber encapsulated wedge
- Clockwise closing direction
- Fusion bonded epoxy coated inside and outside
- Product color: Blue RAL 5017
- Maximum temperature 80°C

Technical Specification

- Design: DIN 3352
- Face to Face : DIN3202 F4/F5
- Flanges: EN 1092-2 PN16
- Hydraulic test to ISO 5208
Seat Test Pressure: 17.6 bar
Shell Test Pressure: 24 bar
Operating torque test

Optional Extras:

- Stem Cap
- Position Indicator
- ISO Top Flange
- Extension Spindle / T Key
- Gear Box
- By-Pass Valve

▲ MATERIAL SPECIFICATION

Item	Part Name	Material	Item	Part Name	Material
1	Body	GGG50	11	O-Ring	EPDM/NBR
2	Wedge	DI+EPDM/DI+NBR	13	Stuffing Nut	Brass
3	Wedge Nut	Brass	14	Gland Flange	GGG50
4	Stem	AISI 420	22	Position indicator	Stainless Steel
10	O-Ring	EPDM/NBR	23	Down Bushing	Brass

▲ DIMENSIONS(mm)

Size	L		D	D1	D2	b	n-d	H	H1	W	W.T(kg)	
	F4	F5									F4	F5
DN350	290	550	520	470	429	26.5	16-28	762	852	450	180	225
DN400	310	600	580	525	480	28	16-31	836	926	450	235	294
DN450	330	650	640	585	548	30	20-31	957	1047	640	345	431
DN500	350	700	715	650	609	31.5	20-34	1036	1126	640	415	519
DN600	390	800	840	770	720	36	20-37	1188	1278	640	575	719

DIN3202 F4/F5 Non-Rising Stem Resilient Seated Gate Valve

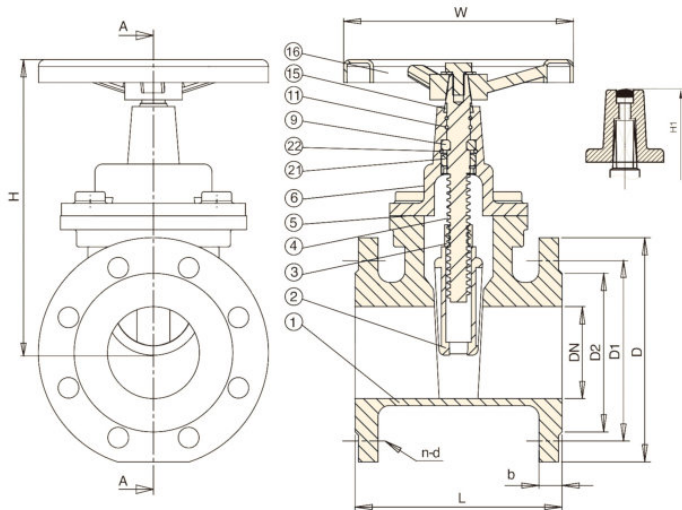

Features

- Bolt Bonnet
- Low torque operation
- Rubber encapsulated wedge
- Clockwise closing direction
- Fusion bonded epoxy coated Inside and outside
- Product color: Blue RAL 5017
- Maximum temperature 80°C

Technical Specification

- Design: DIN 3352
- Face to Face : DIN3202 F4/F5
- Flanges: EN 1092-2 PN16
- Hydraulic test to ISO 5208
Seat Test Pressure: 17.6 bar
Shell Test Pressure: 24 bar
Operating torque test

Optional Extras:

- Stem Cap
- Extension Spindle / T Key

▲ MATERIAL SPECIFICATION

Item	Part Name	Material	Item	Part Name	Material
1	Body	GGG50	5	Bonnet Gasket	EPDM/NBR
2	Wedge	GGG50+EPDM	6	Bonnet	GGG50
		GGG50+NBR	21	Guide Bushing	Nylon
3	Wedge Nut	Brass	22	Circlip	Stainless Steel
4	Stem	AISI 420	11	O-Ring	EPDM/NBR

▲ DIMENSIONS(mm)

Size	L		D	D1	D2	b	n-d	H	H1	W	W.T(kg)	
	F4	F5									F4	F5
DN40	140	240	150	110	88	17	4-18	285	350	140	9	10.4
DN50	150	250	165	125	102	18	4-18	295	335	140	10.5	11
DN65	170	270	185	145	122	18	4-18	328	368	140	12	14
DN80	180	280	200	160	138	18	8-18	350	400	200	16	19
DN100	190	300	220	180	158	19	8-18	400	440	200	21	23
DN125	200	325	250	210	188	19	8-18	428	488	240	25.5	30
DN150	210	350	285	240	212	19	8-22	485	545	240	33	40
DN200	230	400	340	295	268	22	12-22	560	630	295	52	62
DN250	250	450	405	355	320	22	12-26	635	735	360	86	105
DN300	270	500	460	410	378	26	12-26	700	830	360	118	160
DN350	290	550	520	470	438	28	16-26	970	955	460	165	320
DN400	310	600	580	525	490	30	16-30	1020	1070	460	225	420

AS 2638.2 Non-Rising Stem Resilient Seated Gate Valve

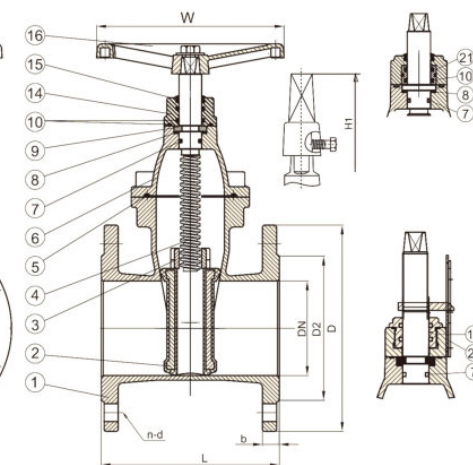
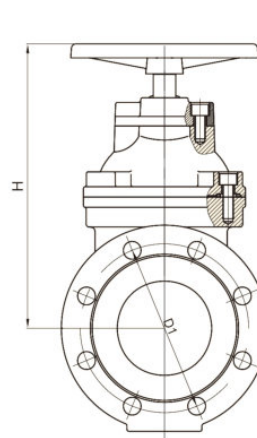

Features

- Replaceable O-ring
- Low torque operation
- Rubber encapsulated wedge
- Clockwise closing direction
- Fusion bonded epoxy coated Inside and outside
- Product color: Blue RAL 5017
- Maximum temperature 80°C

Technical Specification

- Design: AS 2638.2
- Face to Face : AS 2638.2
- Flanges: AS 2129 Table E
- Hydraulic test to ISO 5208
Seat Test Pressure: 17.6 bar
Shell Test Pressure: 24 bar
Operating torque test

Optional Extras:

- Stem Cap
- Position Indicator
- ISO Top Flange
- Extension Spindle / T Key

▲ MATERIAL SPECIFICATION

Item	Part Name	Material	Item	Part Name	Material
1	Body	AS 1831 500-7	11	O-Ring	EPDM/NBR
2	Wedge	DI+EPDM/DI+NBR	13	Stuffing Nut	Brass
3	Wedge Nut	Brass	14	Gland Flange	AS 1831 500-7
4	Stem	AISI 420	22	Position indicator	Stainless Steel
10	O-Ring	EPDM/NBR	23	Down Bushing	Brass

▲ DIMENSIONS(mm)

Size	L	D	D1	D2	b	n-d	H	H1	W	W.T(kg)	
										F4	F5
DN40	165	150	98	78	19	4-14	240	310	180	10.3	
DN50	178	165	114	90	19	4-18	250	320	180	11.5	
DN65	190	185	127	103	19	4-18	265	335	180	15	
DN80	203	200	146	122	19	4-18	300	370	200	18.5	
DN100	229	220	178	154	19	8-18	350	420	200	24	
DN125	254	250	210	186	19	8-18	410	480	250	32	
DN150	267	285	235	208	19	8-22	450	520	280	341	
DN200	292	340	292	263	20	8-22	550	620	320	63	
DN250	330	405	356	328	22	12-22	650	720	350	95	
DN300	356	460	406	378	24.5	12-26	710	780	380	135	



BS 5163 Non-Rising Stem Resilient Seated Gate Valve

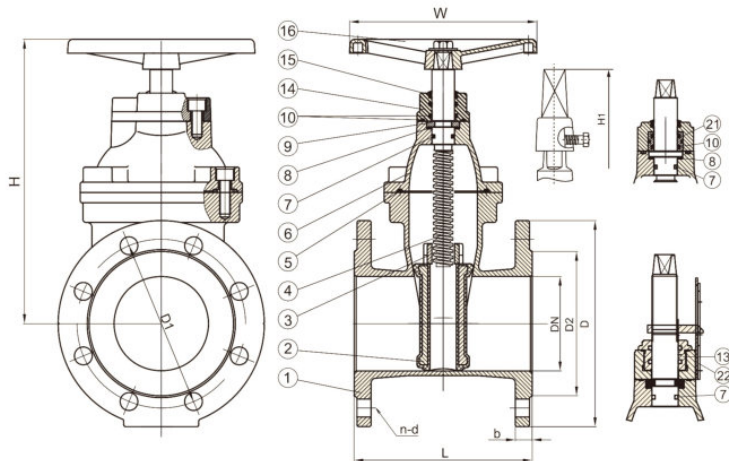

Features

- Replaceable O-ring
- Low torque operation
- Rubber encapsulated wedge
- Clockwise closing direction
- Fusion bonded epoxy coated inside and outside
- Product color: Blue RAL 5017
- Maximum temperature 80°C

Technical Specification

- Design: BS 5163
- Face to Face : BS 5163
- Flanges: EN 1092-2 PN16
- Hydraulic test to ISO 5208
- Seat Test Pressure: 17.6 bar
- Shell Test Pressure: 24 bar
- Operating torque test

Optional Extras:

- Stem Cap
- Position Indicator
- ISO Top Flange
- Extension Spindle / T Key

▲ MATERIAL SPECIFICATION

Item	Part Name	Material	Item	Part Name	Material
1	Body	EN-GJS-500-7	11	O-Ring	EPDM/NBR
2	Wedge	DI+EPDM/NBR	13	Stuffing Nut	Brass
3	Wedge Nut	Brass	14	Gland Flange	EN-GJS-500-7
4	Stem	AISI 420	22	Position indicator	Stainless Steel
10	O-Ring	EPDM/NBR	23	Down Bushing	Brass

▲ DIMENSIONS(mm)

Size	L	D	D1	D2	b	n-d	H	H1	W	W.T(kg)
DN40	165	150	110	88	19	4-19	240	310	180	10.3
DN50	178	165	125	99	19	4-19	250	320	180	11.5
DN65	190	185	145	118	19	4-19	265	335	180	15
DN80	203	200	160	132	19	8-19	300	370	200	18.5
DN100	229	220	180	156	19	8-19	350	420	200	24
DN125	254	250	210	184	19	8-19	410	480	250	32
DN150	267	285	240	211	19	8-23	450	520	280	341
DN200	292	340	295	266	20	12-23	550	620	320	63
DN250	330	405	355	319	22	12-28	650	720	350	95
DN300	356	460	410	370	24.5	12-28	710	780	380	135

BS Big Size Resilient Seated Gate Valve

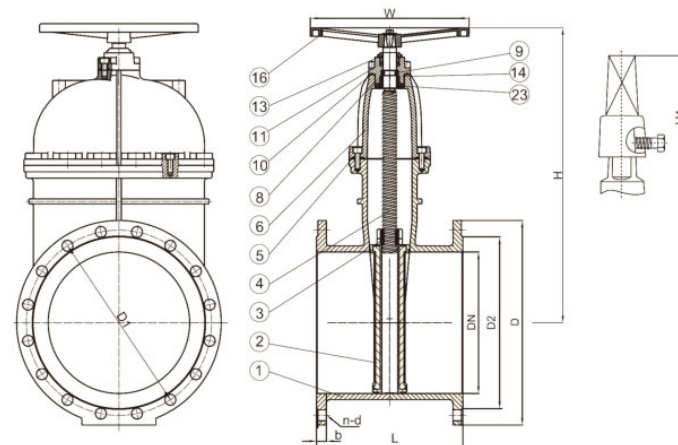

Features

- Replaceable O-ring
- Low torque operation
- Rubber encapsulated wedge
- Clockwise closing direction
- Fusion bonded epoxy coated inside and outside
- Product color: Blue RAL 5017
- Maximum temperature 80°C

Technical Specification

- Design: BS 5163
- Face to Face : BS 5163
- Flanges: EN 1092-2 PN16
- Hydraulic test to ISO 5208
- Seat Test Pressure: 17.6 bar
- Shell Test Pressure: 24 bar
- Operating torque test

Optional Extras:

- Stem Cap
- Position Indicator
- ISO Top Flange
- Extension Spindle / T Key
- Gear Box
- By-Pass Valve

▲ MATERIAL SPECIFICATION

Item	Part Name	Material	Item	Part Name	Material
1	Body	EN-GJS-500-7	11	O-Ring	EPDM/NBR
2	Wedge	DI+EPDM/DI+NBR	13	Stuffing Nut	Brass
3	Wedge Nut	Brass	14	Gland Flange	EN-GJS-500-7
4	Stem	AISI 420	22	Position indicator	Stainless Steel
10	O-Ring	EPDM/NBR	23	Down Bushing	Brass

▲ DIMENSIONS(mm)

Size	L	D	D1	D2	b	n-d	H	H1	W	W.T(kg)
DN350	381	520	470	431	26.5	16-28	762	852	450	216
DN400	406	580	525	482	28	16-31	836	926	450	282
DN450	432	640	585	550	30	20-31	957	1047	640	414
DN500	457	715	650	611	31.5	20-34	1036	1126	640	498
DN600	508	840	770	722	36	20-37	1188	1278	640	690

BS Rising Stem Resilient Seated Gate Valve

Socket Ends Non-rising Resilient Seated Gate Valve

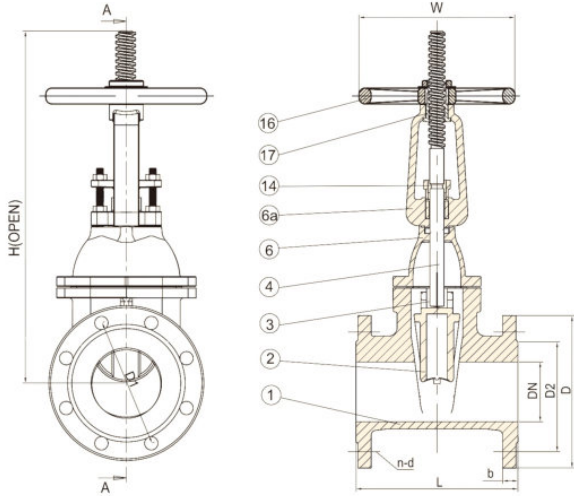

Features

- OutSide stem and yoke (OS&Y)
- Bolt bonnet
- Low torque operation
- Rubber Encapsulated Wedge
- Clockwise closing direction
- Fusion bonded epoxy coated Inside and outside
- Product color: Blue RAL 5017
- Maximum temperature 80°C

Technical Specification

- Design: BS 5163
- Face to Face : BS 5163
- Flanges:EN 1092-2 PN16
- Hydraulic test to ISO 5208
Seat Test Pressure: 17.6 bar
Shell Test Pressure: 24 bar
Operating torque test

▲ MATERIAL SPECIFICATION

Item	Part Name	Material	Item	Part Name	Material
1	Body	EN-GJS-500-7	6	Bonnet	EN-GJS-500-7
2	Wedge	DI+EPDM	6a	Yoke	EN-GJS-500-7
		DI+NBR	14	Gland Flange	EN-GJS-500-7
4	Stem	AISI 420	17	Stem Nut	Brass
5	Bonnet Gasket	EPDM/ NBR			

▲ DIMENSIONS(mm)

Size	L	D	D1	D2	b	n-d	H(open)	W	W.T(KG)
DN40	165	150	110	84	19	4-19	365	180	10.3
DN50	178	165	125	99	19	4-19	385	180	11.5
DN65	190	185	145	118	19	4-19	415	180	15
DN80	203	200	160	132	19	8-19	518	200	18.5
DN100	229	220	180	156	19	8-19	570	200	24
DN125	254	250	210	184	19	8-19	745	250	32
DN150	267	285	240	211	19	8-23	790	280	341
DN200	292	340	295	266	20	12-23	990	320	63
DN250	330	405	355	319	22	12-28	1175	350	95
DN300	356	460	410	370	24.5	12-28	1390	380	135

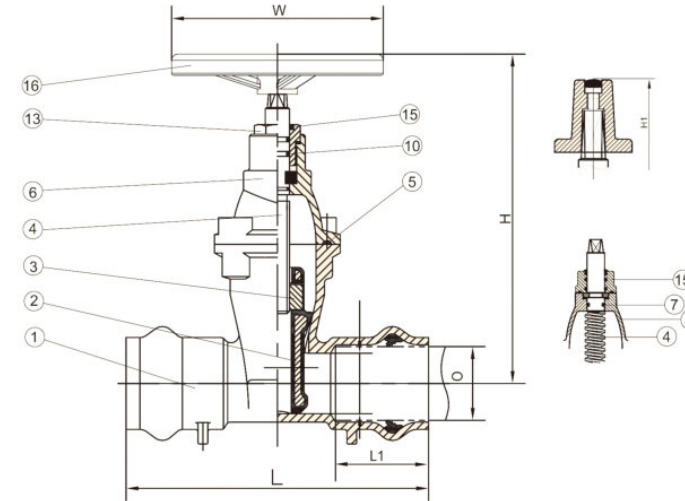

Features

- Bolt Bonnet
- Replaceable O-ring
- Low torque operation
- Rubber encapsulated wedge
- Clockwise closing direction
- IPS PVC Push-on
- Fusion bonded epoxy coated Inside and outside
- Product color: Blue RAL 5017
- Maximum temperature 80°C

Technical Specification

- Design: DIN 3352/SABS 664
- Face to Face : DIN3202 F5
SABS 664
- Hydraulic test to ISO 5208
Seat Test Pressure: 17.6 bar
Shell Test Pressure: 24 bar
Operating torque test

Optional Extras:

- Stem Cap
- Position Indicator
- Extension Spindle / T Key

▲ MATERIAL SPECIFICATION

Item	Part Name	Material	Item	Part Name	Material
1	Body	GGG50	6	Bonnet	GGG50
2	Wedge	DI+EPDM/NBR	7	Back Sealing O Ring	EPDM/NBR
3	Wedge Nut	Brass	13	Stuffing Nut	Brass
4	Stem	AISI 420	15	Gland Flange	GGG50
10	O-Ring	EPDM/ NBR			

▲ DIMENSIONS(mm)

Size	PIPE DIA. O	L		L1	H	H1	W	W.T(kg)	
		F5	SABS					F5	SABS
DN50	63	250	335	77	300	340	180	7.15	9.5
DN65	75	270	335	80	310	350	180	8.25	10.5
DN80	90	280	335	84	350	390	200	12.65	15
DN100	110	300	355	88	380	420	220	18.7	21
DN125	125	325	375	91	420	460	220	23.1	27.5
DN125	140	325	375	91	420	460	220	24.2	28
DN150	160	350	405	94	470	510	250	33	38
DN200	200	400	450	100	590	630	280	45.1	50
DN200	225	400	450	100	590	630	280	47.3	55
DN250	250	450	450	125	680	720	320	67.1	67.1
DN300	315	500	500	140	790	830	360	92.4	92.4

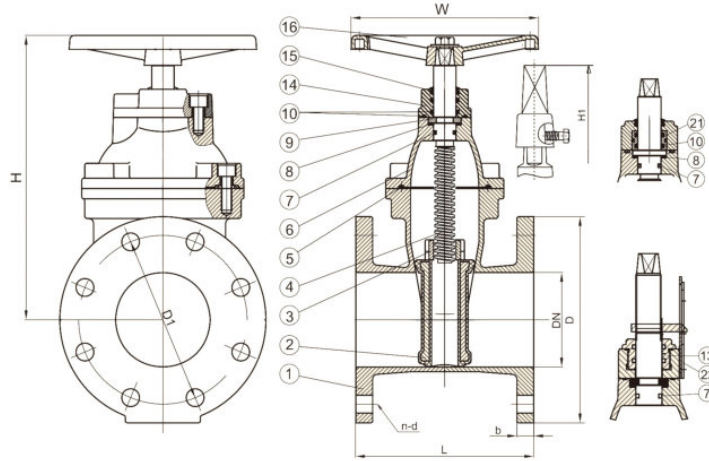

Features

- Replaceable O-ring
- Low torque operation
- Rubber encapsulated wedge
- Clockwise closing direction
- Fusion bonded epoxy coated Inside and outside
- Product color: Blue RAL 5017
- Maximum temperature 80°C

Technical Specification

- Design: AWWA C515/ C509
- Face to Face : ANSI B 16.10
- Flanges: ASME B 16.42
- Hydraulic test to AWWA C509
Seat Test Pressure: 250 Psi
Shell Test Pressure: 500 Psi
Operating torque test

Optional Extras:

- Stem Cap
- Position Indicator
- ISO Top Flange
- Extension Spindle / T Key

AWWA/ANSI 250Psi Non-Rising Stem Resilient Seated Gate Valve

▲ MATERIAL SPECIFICATION

Item	Part Name	Material	Item	Part Name	Material
1	Body	ASTM A536 65-45-12	13	Stuffing Nut	ASTM B16 C36000
2	Wedge	DI+EPDM/NBR	14	Gland Flange	ASTM A536 65-45-12
3	Wedge Nut	ASTM B16 C36000	15	Dust Guard	EPDM/NBR
4	Stem	AISI 420	21	Stuffing Bearing	ASTM B16 C36000
10	O-Ring	EPDM/NBR	22	Position indicator	Stainless Steel

▲ DIMENSIONS(mm)

Size	L	D	D1	b	n-d	H	H1	W	W.T(kg)
1 1/2"	165	127	98.5	14.2	4-16	250	320	180	13
2"	178	152	120.7	15.8	4-19	255	325	180	14
2 1/2"	191	178	139.7	17.5	4-19	280	350	180	16
3"	203	191	152.4	19.0	4-19	300	370	200	23
4"	229	229	190.5	23.9	8-19	344	414	230	28
5"	254	254	215.9	23.9	8-22	410	480	250	37
6"	267	279	241.3	25.4	8-22	441	511	280	52
8"	292	343	298.5	28.5	8-22	529	599	320	77
10"	330	406	362	30.2	12-25	614	684	360	127
12"	356	483	431.8	31.8	12-25	700	770	500	176
14"	381	533	476.3	35.0	12-29	880	950	500	322
16"	406	597	539.8	36.6	16-29	990	1060	500	432
18"	432	635	577.9	39.6	16-32	1120	1200	500	542
20"	457	699	635	42.9	20-32	1220	1300	500	695
24"	508	813	749.3	47.8	20-35	1370	1470	500	845

AWWA/ANSI 250Psi Rising Stem Resilient Seated Gate Valve

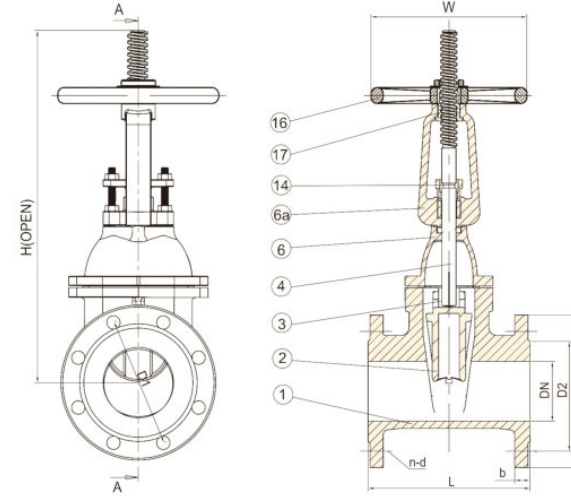

Features

- OutSide stem and yoke (OS&Y)
- Bolt bonnet
- Low torque operation
- Rubber encapsulated wedge
- Clockwise closing direction
- Fusion bonded epoxy coated Inside and outside
- Product color: Blue RAL 5017
- Maximum temperature 80°C

Technical Specification

- Design: AWWA C515/ C509
- Face to Face : ANSI B 16.10
- Flanges: ASME B 16.42
- Hydraulic test to AWWA C509
Seat Test Pressure: 250 Psi
Shell Test Pressure: 500 Psi
Operating torque test

▲ MATERIAL SPECIFICATION

Item	Part Name	Material	Item	Part Name	Material
1	Body	ASTM A536 65-45-12	6	Bonnet	ASTM A536 65-45-12
2	Wedge	DI+EPDM	6a	Yoke	ASTM A536 65-45-12
		DI+NBR	14	Gland Flange	ASTM A536 65-45-12
4	Stem	AISI 420	17	Stem Nut	Brass
5	Bonnet Gasket	EPDM/ NBR			

▲ DIMENSIONS(mm)

Size	L	D	D1	D2	b	n-d	H(open)	W	W.T(kg)
1 1/2"	165	150	98.5	73	19	4-16	365	180	16
2"	178	165	120.7	92	19	4-19	385	180	18
2 1/2"	191	185	139.7	105	19	4-19	415	180	21
3"	203	200	152.4	127	19	4-19	518	205	30
4"	229	229	190.5	157	19	8-19	570	240	35
5"	254	250	215.9	186	19	8-22	745	240	48
6"	267	285	241.3	216	19	8-22	790	280	60
8"	292	340	298.5	270	20	8-22	990	320	85
10"	330	405	362	324	22	12-25	1175	360	139
12"	356	483	431.8	381	24.5	12-25	1390	450	194

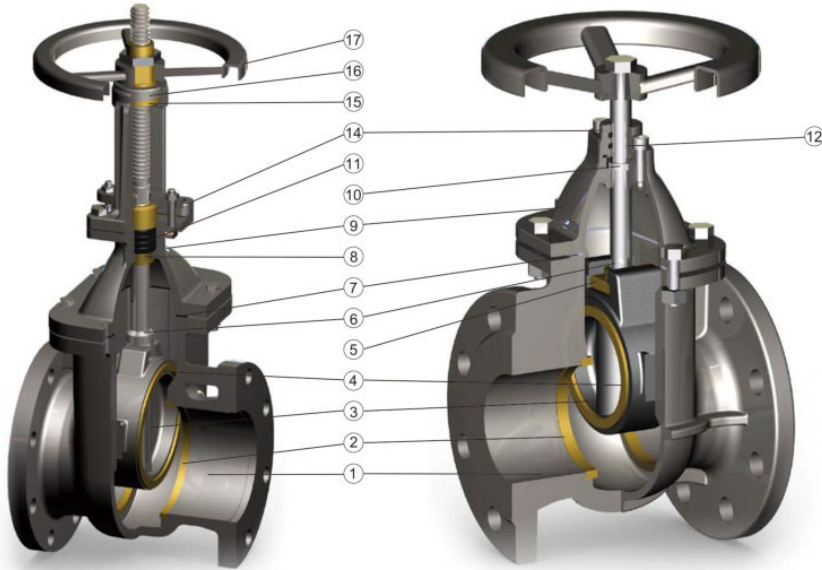

Body

Oval bore design to ensure good compression and deformation resist performance. Body surface with painting to ensure good ageing resistance & weather resisting property.

Seat

Embedded type seat, safety and integrated.

Disc

Disc with guide groove to protect the sealing face, also to ensure on-off freely.

Gasket

Compound Graphite gasket, good performance and long service life.

Bolt, Nut, Half Ring

Stem is oriented by half ring and double bolt&nut to ensure the disc on-off freely.

Handwheel

Handwheel with tapered square hole, easy to install and fasten.

Packing

Soft graphite, long service life, easy to seal and maintain.

Stem Nut

Copper stem nut, good anticorrosion performance.

Stem sealing

1、 Replaceable O-ring stem sealing low open torque, easy to maintain.

2、 Graphite stem sealing long service life, easy to maintain, high temperature resistant.



◆ **Application :**

The series of gate valve is specially designed to suit for transportation, distribution and extraction system in water, air, low pressure steam, gas and petroleum industry, not recommend for steam service.

◆ **Normal Features:**

1. Brass or Bronze Seat Ring.
2. Non-Asbestos Packing and Gasket.
3. Disc seat ring in all sizes are pressed into disc.
4. Big flow area, small flow resistance coefficient and good leak tightness in high pressure.
5. Widely use field, good adaptability.
6. No direction demand, easy to install in pipe.
7. Good material washability.

◆ **Materials & Specifications**

Item No.	Part Name	Material	Specification	
1	Body	Cast Iron	GG25(EN-GJL-250)	ASTM A126B
		Ductile Iron	GGG50(EN-GJS-500-7)	ASTM A536 65-45-12
2	Seat Ring	Brass	CuZn39Pb3	
		Bronze	EN 1982 CC491K	ASTM B62 C83600
		Stainless Steel		
3	Wedge	Cast Iron	GG25(EN-GJL-250)	ASTM A126B
		Ductile Iron	GGG50(EN-GJS-500-7)	ASTM A536 65-45-12
4	Wedge Ring	Brass	CuZn39Pb3	
		Bronze	EN 1982 CC491K	ASTM B62 C83600
		Stainless Steel		
5	Wedge Nut	Brass	COPPER ALLOY EN 12165	ASTM B16 C36000
6	Stem	Stainless Steel	X20 Cr13	SS AISI 420
		Brass	CuZn39Pb3	ASTM B16 C36000
7	Bonnet Gasket	Graphite		
		Graphite With Soft Steel		
8	Back Seat	Bronze	EN 1982 CC491K	ASTM B62 C83600
9	Bonnet	Cast Iron	GG25(EN-GJL-250)	ASTM A126B
		Ductile Iron	GGG50(EN-GJS-500-7)	ASTM A536 65-45-12
10	Stem Collar	Stainless Steel	X20 Cr13	SS AISI 420
11	Packing	Graphite	Non-asbestos	Non-asbestos
12	Stem Sealing	EPDM O-Ring		
13	Stuffing Box	Ductile Iron	GGG50(EN-GJS-500-7)	ASTM A536 65-45-12
14	Gland Flange	Ductile Iron	GGG50(EN-GJS-500-7)	ASTM A536 65-45-12
15	Stem Nut	Brass	COPPER ALLOY EN 12165	ASTM B16 C36000
16	Retaining Nut	Cast Iron	GG25(EN-GJL-250)	ASTM A126B
17	HandWheel	Ductile Iron	GGG50(EN-GJS-500-7)	ASTM A536 65-45-12



Features

- Bolt Bonnet
- Solid wedge disc
- Replaceable O-ring
- Clockwise closing direction
- Seat rings are pressed into wedge and body
- Product color: Blue RAL 5017
- Maximum temperature 80°C

Technical Specification

- Design: DIN 3352
- Face to Face : DIN3202 F4
- Flanges: EN 1092-2 PN10
- Hydraulic test to ISO 5208
Seat Test Pressure: 11 bar
Shell Test Pressure: 15 bar

Optional Extras:

- Position Indicator

DIN 3352 F4 Non-Rising Stem Metal Seated Gate Valve Type B

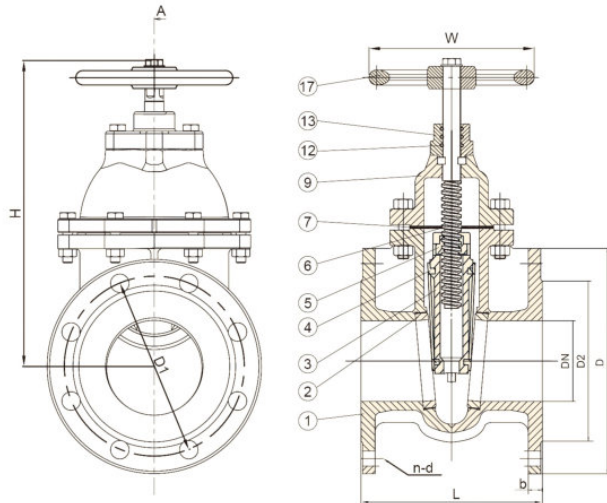

▲ MATERIAL SPECIFICATION

Item	Part Name	Material	Item	Part Name	Material
1	Body	EN-GJL-250	6	Stem	AISI 420
2	Seat Ring	Brass	7	Bonnet Gasket	Graphite
3	Wedge	EN-GJL-250	9	Bonnet	EN-GJL-250
4	Wedge Ring	Brass	12	Stem Sealing	EPDM O-Ring
5	Wedge Nut	Brass	13	Gland Flange	EN-GJL-250

▲ DIMENSIONS(mm)

Size	L	D	D1	D2	b	n-d	H	W	W.T(kg)
DN40	140	150	110	84	18	4-19	230	130	11
DN50	150	165	125	99	20	4-19	250	130	12
DN65	170	185	145	118	20	4-19	280	130	16
DN80	180	200	160	132	22	8-19	310	150	19
DN100	190	220	180	156	24	8-19	349	185	26
DN125	200	250	210	184	26	8-19	395	185	36
DN150	210	285	240	211	26	8-23	456	195	51
DN200	230	340	295	266	26	8-23	537	225	62
DN250	250	395	350	319	28	12-23	659	245	127
DN300	270	445	400	370	28	12-23	718	285	165
DN350	290	505	460	429	30	16-23	870	400	225
DN400	310	565	515	480	32	16-28	941	400	369.6
DN450	330	615	565	530	32	20-28	1204	640	426.8
DN500	350	670	620	582	34	20-28	1295	640	572
DN600	390	780	725	682	36	20-31	1478	640	809.6



Features

- Bolt Bonnet
- Solid wedge disc
- Graphite packing
- Clockwise closing direction
- Seat rings are pressed into wedge and body
- Product color: Blue RAL 5017
- Maximum temperature 150 °C

Technical Specification

- Design: DIN 3352
- Face to Face : DIN3202 F4
- Flanges: EN 1092-2 PN10
- Hydraulic test to ISO 5208
Seat Test Pressure: 11 bar
Shell Test Pressure: 15 bar

Optional Extras:

- Position Indicator

DIN 3352 F4 Non-Rising Stem Metal Seated Gate Valve Type C

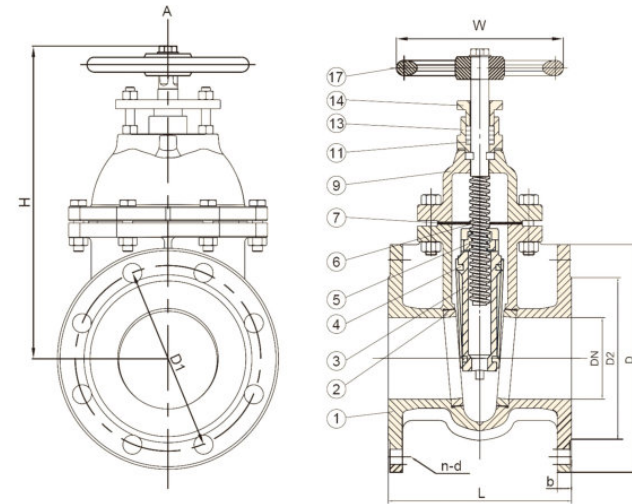

▲ MATERIAL SPECIFICATION

Item	Part Name	Material	Item	Part Name	Material
1	Body	EN-GJL-250	7	Bonnet Gasket	Graphite
2	Seat Ring	Brass	9	Bonnet	EN-GJL-250
3	Wedge	EN-GJL-250	11	Packing	Graphite
4	Wedge Ring	Brass	13	Stuffing Box	EN-GJL-250
6	Stem	AISI 420	14	Gland Follower	EN-GJL-250

▲ DIMENSIONS(mm)

Size	L	D	D1	D2	b	n-d	H	W	W.T(kg)
DN40	140	150	110	84	18	4-19	250	130	11
DN50	150	165	125	99	20	4-19	270	130	12
DN65	170	185	145	118	20	4-19	300	130	16
DN80	180	200	160	132	22	8-19	330	150	19
DN100	190	220	180	156	24	8-19	369	185	26
DN125	200	250	210	184	26	8-19	415	185	36
DN150	210	285	240	211	26	8-23	476	195	51
DN200	230	340	295	266	26	8-23	557	225	62
DN250	250	395	350	319	28	12-23	679	245	127
DN300	270	445	400	370	28	12-23	738	285	165
DN350	290	505	460	429	30	16-23	870	400	225
DN400	310	565	515	480	32	16-28	941	400	369.6
DN450	330	615	565	530	32	20-28	1204	640	426.8
DN500	350	670	620	582	34	20-28	1295	640	572
DN600	390	780	725	682	36	20-31	1478	640	809.6

DIN 3352 F4 Non-Rising Stem Metal Seated Gate Valve Type D

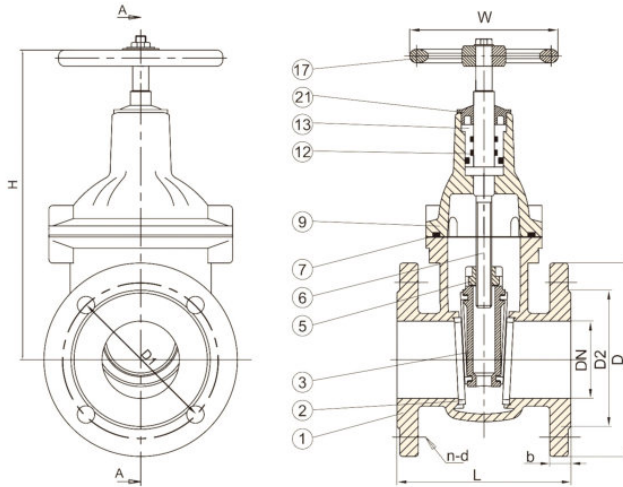

Features

- Bolt Bonnet
- Clockwise closing direction
- Solid wedge disc
- Replaceable O-ring
- Seat rings are pressed into Bodies
- Product color: Blue RAL 5017
- Maximum temperature 80°C

Technical Specification

- Design: DIN 3352
- Face to Face : DIN3202 F4
- Flanges: DIN 2532 PN10
- Hydraulic test to ISO 5208
Seat Test Pressure: 11 bar
Shell Test Pressure: 15 bar

▲ MATERIAL SPECIFICATION

Item	Part Name	Material	Item	Part Name	Material
1	Body	EN-GJL-250	6	Stem	AISI 420
2	Seat Ring	Brass	7	Bonnet Gasket	EPDM
3	Wedge	CI+Brass	9	Bonnet	EN-GJL-250
5	Wedge Nut	Brass	12	Stem Sealing	EPDM O-Ring
21	Dust Guard	EPDM/NBR	13	Stuffing Nut	Brass

▲ DIMENSIONS(mm)

Size	L	D	D1	D2	b	n-d	H	W	W.T(kg)
DN40	140	150	110	88	16	4-18	260	130	8.6
DN50	150	165	125	102	18	4-18	265	130	10.9
DN65	170	185	145	122	18	4-18	293	130	14.2
DN80	180	200	160	138	20	8-18	318	150	20.3
DN100	190	220	180	158	20	8-18	349	185	22.8
DN125	200	250	210	188	20	8-18	416	185	33.9
DN150	210	285	240	212	22	8-22	456	195	42.0
DN200	230	340	295	268	24	8-22	537	225	63.4
DN250	250	395	350	320	26	12-22	659	245	91.8
DN300	270	445	400	370	26	12-22	718	285	138.6

DIN 3352 F4 Rising Stem Solid Wedge Gate Valve

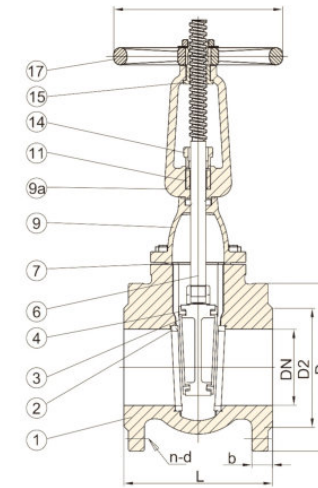
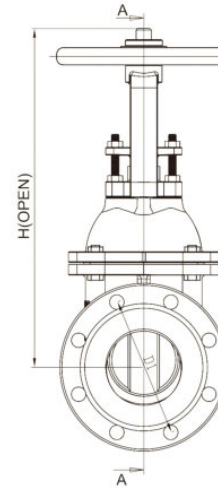

Features

- Bolt Bonnet
- Solid wedge disc
- Outside screw and yoke
- Clockwise closing direction
- Graphite packing
- Seat rings are pressed into wedge and body
- Product color: Blue RAL 5017
- Maximum temperature 150°C

Technical Specification

- Design: DIN 3352
- Face to Face : DIN3202 F4
- Flanges: EN 1092-2 PN10
- Hydraulic test to ISO 5208
Seat Test Pressure: 11 bar
Shell Test Pressure: 15 bar

▲ MATERIAL SPECIFICATION

Item	Part Name	Material	Item	Part Name	Material
1	Body	EN-GJL-250	7	Bonnet Gasket	Graphite
2	Seat Ring	Brass	9	Bonnet	EN-GJL-250
3	Wedge	EN-GJL-250	9a	Yoke	EN-GJL-250
4	Wedge Ring	Brass	11	Packing	Graphite
6	Stem	AISI 420	14	Gland Follower	EN-GJS-500-7

▲ DIMENSIONS(mm)

Size	L	D	D1	D2	b	n-d	H(open)	W	W.T(kg)
DN40	140	150	110	84	18	4-19	340	180	13
DN50	150	165	125	99	20	4-19	354	180	14
DN65	170	185	145	118	20	4-19	390	180	18.5
DN80	180	200	160	132	22	8-19	435	200	25.1
DN100	190	220	180	156	24	8-19	545	200	32.3
DN125	200	250	210	184	26	8-19	625	250	44.6
DN150	210	285	240	211	26	8-23	750	280	59.2
DN200	230	340	295	266	26	8-23	980	300	88
DN250	250	395	350	319	28	12-23	1130	360	138
DN300	270	445	400	370	28	12-23	1330	400	177.5
DN350	290	505	460	429	30	16-23	1533	450	240
DN400	310	565	515	480	32	16-28	1905	450	420
DN450	330	615	565	530	32	20-28	2072	640	485
DN500	350	670	620	582	34	20-28	2302	640	650
DN600	390	780	725	682	36	20-31	2650	900	920

DIN 3352 F5 Non-Rising Stem Metal Seated Gate Valve

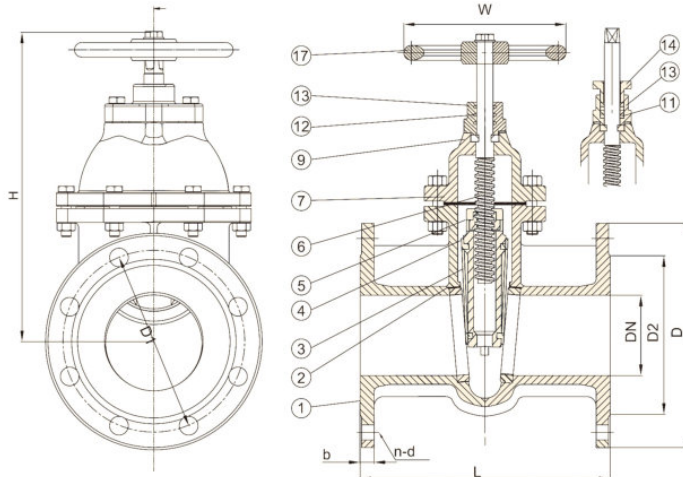

Features

- Bolt Bonnet
- Solid wedge disc
- Replaceable O-ring or Graphite packing
- Clockwise closing direction
- Seat rings are pressed into wedge and body
- Product color: Blue RAL 5017
- Maximum temperature 150 °C

Technical Specification

- Design: DIN 3352
- Face to Face : DIN3202 F5
- Flanges:EN 1092-2 PN16
- Hydraulic test to ISO 5208
Seat Test Pressure: 17.6 bar
Shell Test Pressure: 24 bar

Optional Extras:

- Position Indicator

▲ MATERIAL SPECIFICATION

Item	Part Name	Material	Item	Part Name	Material
1	Body	EN-GJL-250	7	Bonnet Gasket	Graphite
2	Seat Ring	Brass	11	Packing	Graphite
3	Wedge	EN-GJL-250	12	Stem Sealing	EPDM O-Ring
4	Wedge Ring	Brass	13	Stuffing Box	EN-GJL-250
6	Stem	AISI 420	14	Gland Follower	EN-GJL-250

▲ DIMENSIONS(mm)

Size	L	D	D1	D2	b	n-d	H	W	W.T(kg)
DN40	240	150	110	84	18	4-19	230	150	12.0
DN50	250	165	125	99	20	4-19	250	150	13.9
DN65	270	185	145	118	20	4-19	280	150	17.9
DN80	280	200	160	132	22	8-19	310	180	22.9
DN100	300	220	180	156	24	8-19	349	195	29.2
DN125	325	250	210	184	26	8-19	395	195	47.4
DN150	350	285	240	211	26	8-23	456	225	53.3
DN200	400	340	295	266	30	12-23	537	225	80.6
DN250	450	405	355	319	32	12-28	659	285	123.9
DN300	500	460	410	370	32	12-28	718	400	175.4
DN350	550	520	470	429	36	16-28	870	400	270.0
DN400	600	580	525	480	38	16-31	941	400	462.0

DIN 3352 F5 Big Size Metal Seated Gate Valve (DN350-DN1200)

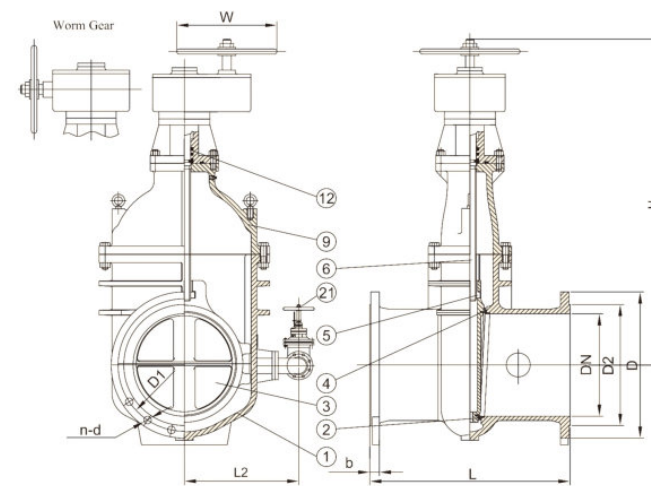

Features

- Bolt Bonnet
- Solid wedge disc
- Replaceable O-ring
- Clockwise closing direction
- Seat rings are pressed into wedge and body
- Product color: Blue RAL 5017
- Maximum temperature 80 °C

Technical Specification

- Design: DIN 3352
- Face to Face : DIN3202 F5
- Flanges:EN 1092-2 PN16
- Hydraulic test to ISO 5208
Seat Test Pressure: 17.6 bar
Shell Test Pressure: 24 bar

Optional Extras:

- Position Indicator
- ISO Top Flange
- Gear box
- By-Pass Valve

▲ MATERIAL SPECIFICATION

Item	Part Name	Material	Item	Part Name	Material
1	Body	GGG50	6	Stem	AISI 420
2	Seat Ring	Brass	9	Bonnet	GGG50
3	Wedge	GGG50	12	Stem Sealing	EPDM O-Ring
4	Wedge Ring	Brass	21	By-Pass Valve	
5	Wedge Nut	Brass			

▲ DIMENSIONS(mm)

Size(DN)	L	D	D1	D2	b	n-d	L2	H	W	W.T(kg)
DN350	550	520	470	429	26.5	16-28	600	1082	460	390
DN400	600	580	525	480	28	16-31	600	1123	600	498
DN450	650	640	585	548	30	20-31	620	1204	600	521
DN500	700	715	650	609	31.5	20-34	660	1295	600	699
DN600	800	840	770	720	36	20-37	722	1478	600	1010
DN700	900	910	840	794	39.5	24-37	833	1696	720	2243
DN800	1000	1025	950	901	43	24-41	863	1816	720	2895
DN900	1100	1125	1050	1001	46.5	28-41	972	2323	720	3380
DN1000	1200	1255	1170	1112	50	28-44	1015	2611	720	4683
DN1200	1400	1485	1390	1328	57	32-50	1065	2718	900	6582



Features

- Bolt bonnet
- Solid wedge
- Outside screw and yoke
- Clockwise closing direction
- Graphite packing
- Seat Rings are pressed into wedge and body
- Product color: Blue RAL 5017
- Maximum temperature 150°C

Technical Specification

- Design: DIN 3352
- Face to Face : DIN3202 F5
- Flanges: EN 1092-2 PN16
- Hydraulic test to ISO 5208
Seat Test Pressure: 17.6 bar
Shell Test Pressure: 24 bar
Operating torque test

DIN 3352 F5 Rising Stem Solid Wedge Gate Valve

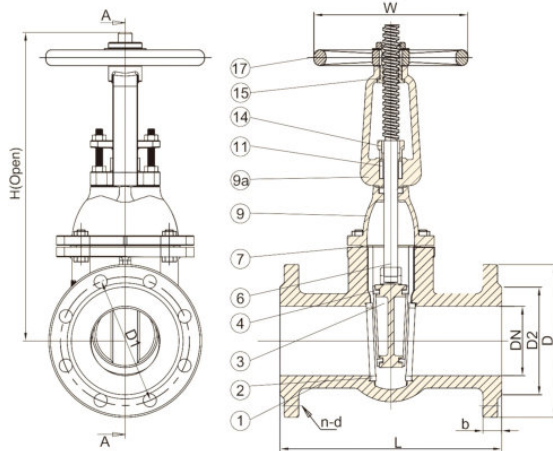

▲ MATERIAL SPECIFICATION

Item	Part Name	Material	Item	Part Name	Material
1	Body	EN-GJL-250	7	Bonnet Gasket	Graphite
2	Seat Ring	Brass	10	Bonnet	EN-GJL-250
3	Wedge	EN-GJL-250	10a	Yoke	EN-GJL-250
4	Wedge Ring	Brass	12	Packing	Graphite
6	Stem	AISI 420	14	Gland Follower	EN-GJL-250

▲ DIMENSIONS(mm)

Size	L	D	D1	D2	b	n-d	H(open)	W	W.T(kg)
DN40	240	150	110	84	18	4-19	340	180	15
DN50	250	165	125	99	20	4-19	354	180	17.3
DN65	270	185	145	118	20	4-19	390	180	21.5
DN80	280	200	160	132	22	8-19	435	200	28.1
DN100	300	220	180	156	24	8-19	545	200	35.9
DN125	325	250	210	184	26	8-19	625	250	50.6
DN150	350	285	240	211	26	8-23	750	280	71.2
DN200	400	340	295	266	30	12-23	980	300	83
DN250	450	405	355	319	32	12-28	1130	360	147
DN300	500	460	410	370	32	12-28	1330	400	210
DN350	550	520	470	429	36	16-28	1533	450	280
DN400	600	580	525	480	38	16-31	1905	450	487.2
DN450	650	640	585	548	40	20-31	2072	640	562.6
DN500	700	715	650	609	42	20-34	2302	640	754.0
DN600	800	840	770	720	48	20-37	2650	900	1067.2



Features

- Bolt bonnet
- Solid wedge
- Outside screw and yoke
- Clockwise closing direction
- Graphite packing
- Seat rings are pressed into wedge and body
- Product color: Blue RAL 5017
- Maximum temperature 150°C

Technical Specification

- Design: JIS B2044
- Face to Face : JIS B2002
- Flanges: JIS B2212 10K
- Hydraulic test to JIS B2003
Seat Test Pressure: 15.4 Bar
Shell Test Pressure: 21 Bar

JIS 10K Rising Stem Solid Wedge Gate Valve

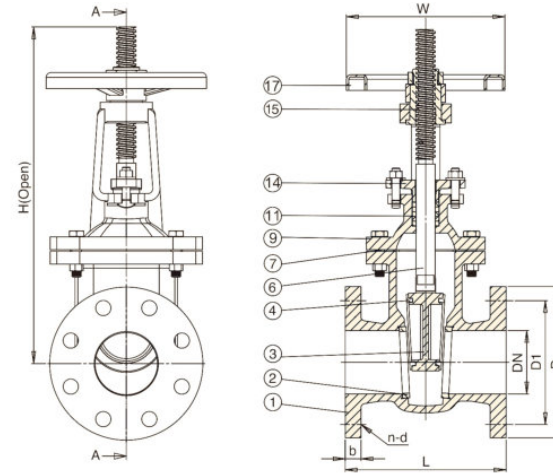

▲ MATERIAL SPECIFICATION

Item	Part Name	Material	Item	Part Name	Material
1	Body	FC20	7	Bonnet Gasket	Graphite
2	Seat Ring	Bronze B62	9	Bonnet	FC20
3	Wedge	FC20	11	Packing	Graphite
4	Wedge Ring	Bronze B62	14	Gland Follower	FCD45
6	Stem	AISI 420	15	Stem Nut	Brass

▲ DIMENSIONS(mm)

Size	L	D	D1	b	n-d	H(open)	W	W.T(kg)
DN40	165	140	105	20	4-19	320	180	14.5
DN50	178	155	120	20	4-19	347	180	17
DN65	190	175	140	22	4-19	390	190	18
DN80	203	185	150	22	8-19	470	200	24.8
DN100	229	210	175	24	8-19	535	200	34.6
DN125	254	250	210	24	8-23	644	250	50.4
DN150	267	280	240	26	8-23	739	280	63
DN200	292	330	290	26	12-23	936	300	92
DN250	330	400	355	30	12-25	1133	360	149
DN300	356	445	400	32	16-25	1330	400	197.5
DN350	381	490	445	34	16-25	1533	450	261.5
DN400	406	560	510	36	16-27	1905	450	441
DN450	432	620	565	38	20-27	2072	640	509.3
DN500	457	675	620	40	20-27	2302	640	682.5



ANSI 125/150 Rising Stem Metal Seated Solid Wedge Gate Valve

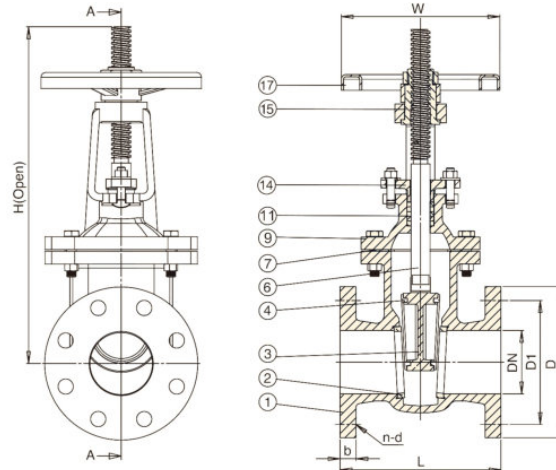

Features

- Bolt bonnet
- Solid wedge
- Graphite packing
- Outside screw and yoke
- Clockwise closing direction
- Seat rings are pressed into wedge and body
- Product color: Blue RAL 5017
- Maximum temperature 150°C

▲ MATERIAL SPECIFICATION

Item	Part Name	Material	Item	Part Name	Material
1	Body	ASTM A126B	7	Bonnet Gasket	Graphite
2	Seat Ring	Bronze B62/ Brass	9	Bonnet	ASTM A126B
3	Wedge	ASTM A126B	11	Packing	Graphite
4	Wedge Ring	Bronze B62/ Brass	14	Gland Follower	ASTM A536 65-45-12
6	Stem	AISI 420	15	Stem Nut	Brass

▲ DIMENSIONS(mm)

Size	L	D	D1	b	n-d	H(open)	W	W.T(kg)
1 1/2"	165.1	127	98.6	14.2	4-16	320	180	13.6
2"	177.8	152	120.7	15.8	4-19	330	180	17.0
2 1/2"	190.5	178	139.7	17.5	4-19	385	180	18.0
3"	203.2	191	152.4	19	4-19	420	200	24.8
4"	228.6	229	190.5	23.9	8-19	500	200	34.6
5"	254.0	254	215.9	23.9	8-22	660	250	50.4
6"	266.7	279	241.3	25.4	8-22	740	280	63.0
8"	292.1	343	298.5	28.5	8-22	930	300	92.0
10"	330.2	406	362	30.2	12-25	1130	360	149.0
12"	355.6	483	431.8	31.8	12-25	1330	400	197.5
14"	381.0	533	476.3	35	12-29	1533	450	261.5
16"	406.4	597	539.8	36.6	16-29	1905	450	441.0
18"	431.8	635	577.9	39.6	16-32	2072	640	509.3

ANSI 125/150 Non-Rising Stem Metal Seated Gate Valve

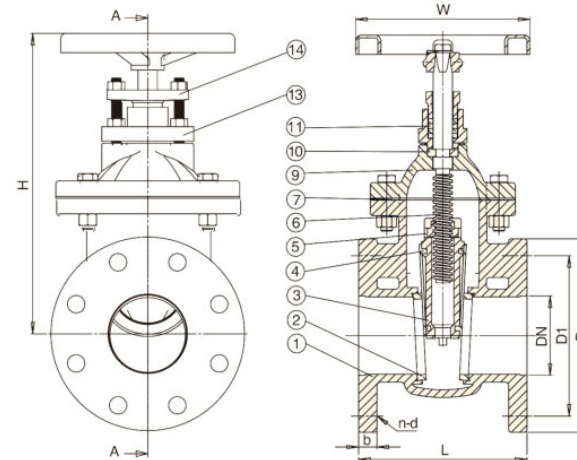

Features

- Bolt bonnet
- Clockwise closing direction
- Solid wedge
- Graphite packing
- Seat rings are pressed into wedge and body
- Product color: Blue RAL 5017
- Maximum temperature 150°C

▲ MATERIAL SPECIFICATION

Item	Part Name	Material	Item	Part Name	Material
1	Body	ASTM A126B	7	Bonnet Gasket	Graphite
2	Seat Ring	Bronze B62/ Brass	9	Bonnet	ASTM A126B
3	Wedge	ASTM A126B	11	Packing	Graphite
4	Wedge Ring	Bronze B62/ Brass	13	Stuffing Box	ASTM A126B
6	Stem	AISI 420	14	Gland Follower	ASTM A536 65-45-12

▲ DIMENSIONS(mm)

Size	L	D	D1	b	n-d	H(open)	W	W.T(kg)
1 1/2"	165.1	127	98.6	14.2	4-16	240	180	13.0
2"	177.8	152	120.7	15.8	4-19	250	180	15.0
2 1/2"	190.5	178	139.7	17.5	4-19	265	180	18.5
3"	203.2	191	152.4	19	4-19	300	200	24.9
4"	228.6	229	190.5	23.9	8-19	350	200	34.8
5"	254.0	254	215.9	23.9	8-22	410	250	48.0
6"	266.7	279	241.3	25.4	8-22	450	280	61.3
8"	292.1	343	298.5	28.5	8-22	550	300	106.0
10"	330.2	406	362	30.2	12-25	650	360	138.0
12"	355.6	483	431.8	31.8	12-25	710	400	175.0
14"	381.0	533	476.3	35	12-29	1000	450	240.0
16"	406.4	597	539.8	36.6	16-29	1123	450	420.0
18"	431.8	635	577.9	39.6	16-32	1204	640	485.0

Technical Specification

- Design: MSS SP-70
- Face to Face : ANSI B16.10
- Flanges:ANSI B16.1
- Hydraulic test to MSS SP-70
Seat Test Pressure: 220 Psi
Shell Test Pressure: 350 Psi



ANSI 125/150 Rising Stem Solid Wedge Gate Valve Type B

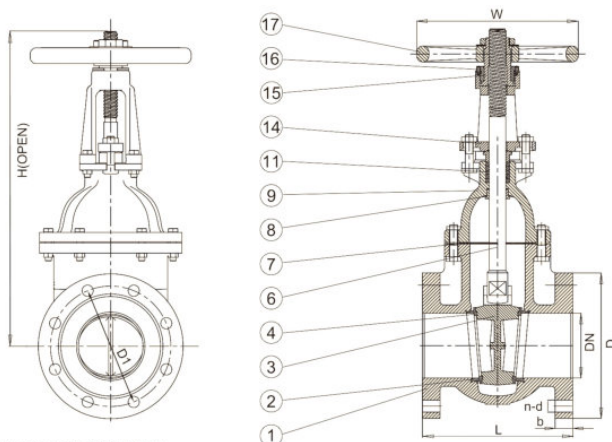

Features

- Solid wedge
- Back seating design
- Outside screw and yoke
- Stem nut assembled downward
- Gland flange has two-piece construction
- Clockwise closing direction
- Seat rings are pressed into wedge and body
- Product color: Blue RAL 5017
- Maximum temperature 178 °C

Technical Specification

- Design: MSS SP-70
- Face to Face : ANSI B16.10
- Flanges: ANSI B16.1
- Hydraulic test to MSS SP-70
Seat Test Pressure: 220 Psi
Shell Test Pressure: 350 Psi

Optional Extras:

- Gear Box
- By-Pass Valve

▲ MATERIAL SPECIFICATION

Item	Part Name	Material	Item	Part Name	Material
1	Body	ASTM A126B	9	Back Seat	Bronze
2	Seat Ring	Bronze B62/ Brass	12	Packing	Graphite
4	Wedge Ring	Bronze B62/ Brass	14	Gland Follower	ASTM A536 65-45-12
6	Stem	AISI 420	15	Stem Nut	Brass
7	Bonnet Gasket	Graphite	16	Retaining Nut	ASTM A126B

▲ DIMENSIONS(mm)

Size	L	D	D1	b	n-d	H(open)	W	W.T(kg)
1 1/2"	165.1	127	98.6	14.2	4-16	400	178	18.0
2"	177.8	152	120.7	15.8	4-19	405	178	22.0
2 1/2"	190.5	178	139.7	17.5	4-19	415	178	24.1
3"	203.2	191	152.4	19	4-19	486	190	29.5
4"	228.6	229	190.5	23.9	8-19	632	250	53.2
5"	254.0	254	215.9	23.9	8-22	710	300	80.0
6"	266.7	279	241.3	25.4	8-22	842	300	95.8
8"	292.1	343	298.5	28.5	8-22	1100	356	140.0
10"	330.2	406	362	30.2	12-25	1228	400	251.0
12"	355.6	483	431.8	31.8	12-25	1373	457	365.0
14"	381.0	533	476.3	35	12-29	1595	508	450.0
16"	406.4	597	539.8	36.6	16-29	1900	558	696.0
18"	431.8	635	577.9	39.6	16-32	2210	610	950.0
20"	457.2	699	635	42.9	20-32	2600	610	1089.0
24"	508.0	813	749.3	47.8	20-35	3040	762	1520.0
30"	609.6	984	914.4	53.9	28-35	3400	900	2936.0
36"	711.2	1168	1086	60.5	32-41	3950	900	3600.0

ANSI 125/150 Non-Rising Stem Metal Seated Gate Valve Type B

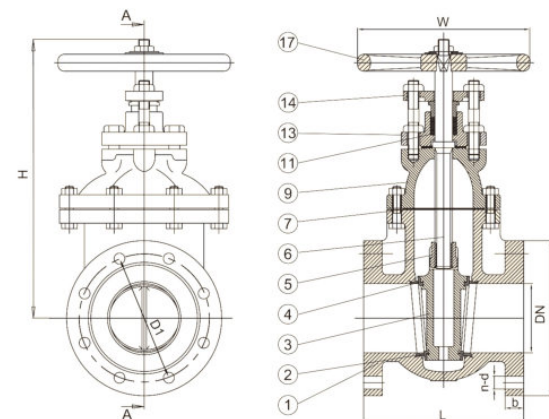

▲ MATERIAL SPECIFICATION

Item	Part Name	Material	Item	Part Name	Material
1	Body	ASTM A126B	7	Bonnet Gasket	Graphite
2	Seat Ring	Bronze B62/ Brass	12	Packing	Graphite
3	Wedge	ASTM A126B	13	Stuffing Box	ASTM A126B
4	Wedge Ring	Bronze B62/ Brass	21	Packing Gland	Brass
6	Stem	AISI 420	14	Gland Follower	ASTM A536 65-45-12

▲ DIMENSIONS(mm)

Size	L	D	D1	b	n-d	H(open)	W	W.T(kg)
1 1/2"	165.1	127	98.6	14.2	4-16	400	178	18
2"	177.8	152	120.7	15.8	4-19	405	178	21.5
2 1/2"	190.5	178	139.7	17.5	4-19	415	178	23.5
3"	203.2	191	152.4	19	4-19	486	190	28.4
4"	228.6	229	190.5	23.9	8-19	632	250	48.2
5"	254.0	254	215.9	23.9	8-22	710	300	68.0
6"	266.7	279	241.3	25.4	8-22	842	300	81.8
8"	292.1	343	298.5	28.5	8-22	1100	356	135.0
10"	330.2	406	362	30.2	12-25	1228	400	213.2
12"	355.6	483	431.8	31.8	12-25	1373	457	313.6
14"	381.0	533	476.3	35	12-29	1595	508	400.0
16"	406.4	597	539.8	36.6	16-29	1900	558	610.0
18"	431.8	635	577.9	39.6	16-32	2210	610	800.0
20"	457.2	699	635	42.9	20-32	2600	610	980.0
24"	508.0	813	749.3	47.8	20-35	3040	762	1320.0
30"	609.6	984	914.4	53.9	28-35	3400	900	2836.0
36"	711.2	1168	1086	60.5	32-41	3950	900	3500.0



Features

- Bolt bonnet
- Solid wedge
- Graphite packing
- Clockwise closing direction
- Gland flange has two-piece construction
- Seat rings are pressed into wedge and body
- Product color: Blue RAL 5017
- Maximum temperature 178°C

Technical Specification

- Design: MSS SP-70
- Face to Face : ANSI B16.10
- Flanges: ANSI B16.1
- Hydraulic test to MSS SP-70
Seat Test Pressure: 220 Psi
Shell Test Pressure: 350 Psi

Optional Extras:

- Position Indicator
- Gear Box
- By-Pass Valve

BS Non-Rising Stem Metal Seated Gate Valve

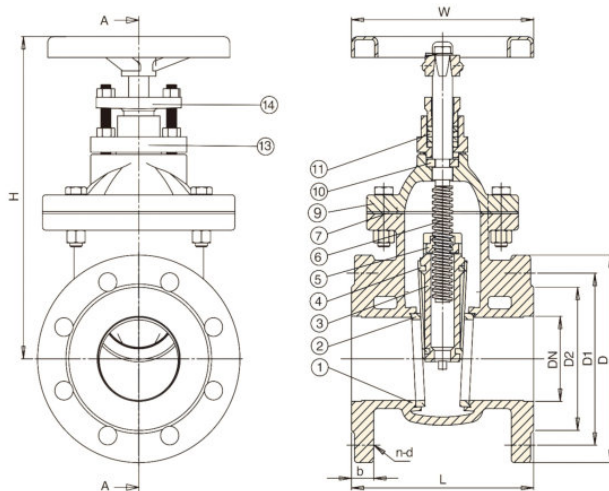

Features

- Bolt bonnet
- Clockwise closing direction
- Solid wedge
- Graphite packing
- Seat rings are pressed into wedge and Body
- Product color: Blue RAL 5017
- Maximum temperature 150°C

▲ MATERIAL SPECIFICATION

Item	Part Name	Material	Item	Part Name	Material
1	Body	EN-GJL-250	7	Bonnet Gasket	Graphite
2	Seat Ring	Bronze B62/ Brass	9	Bonnet	EN-GJL-250
3	Wedge	EN-GJL-250	11	Packing	Graphite
4	Wedge Ring	Bronze B62/ Brass	13	Stuffing Box	EN-GJL-250
6	Stem	AISI 420	14	Gland Follower	EN-GJS-500-7

▲ DIMENSIONS(mm)

Size	L	D	D1	D2	b	n-d	H	W	W.T(kg)
DN40	165	150	110	88	18	4-19	240	180	13
DN50	178	165	125	102	20	4-19	250	180	15
DN65	190	185	145	122	20	4-19	265	180	18.5
DN80	203	200	160	138	22	8-19	300	200	24.9
DN100	229	220	180	158	24	8-19	350	200	34.8
DN125	254	250	210	188	26	8-19	410	250	48
DN150	267	285	240	212	26	8-23	450	280	61.3
DN200	292	340	295	268	30	12-23	550	300	106
DN250	330	405	355	320	32	12-28	650	360	138
DN300	356	460	410	378	32	12-28	710	400	175
DN350	381	520	470	438	36	16-28	1000	450	240
DN400	406	580	525	490	38	16-31	1123	450	420
DN450	432	640	585	548	40	20-31	1204	640	485
DN500	457	715	650	610	42	20-34	1295	640	650
DN600	508	840	770	725	48	30-37	1478	900	920

BS Rising Stem Solid Wedge Gate Valve

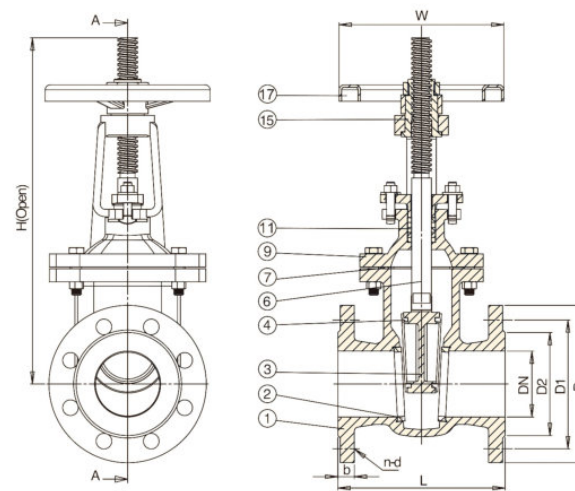

Features

- Bolt bonnet
- Solid wedge
- Outside screw and yoke
- Clockwise closing direction
- Graphite packing
- Seat rings are pressed into wedge and body
- Product color: Blue RAL 5017
- Maximum temperature 150°C

▲ MATERIAL SPECIFICATION

Item	Part Name	Material	Item	Part Name	Material
1	Body	EN-GJL-250	7	Bonnet Gasket	Graphite
2	Seat Ring	Bronze B62/ Brass	9	Bonnet	EN-GJL-250
3	Wedge	EN-GJL-250	11	Packing	Graphite
4	Wedge Ring	Bronze B62/ Brass	14	Gland Follower	EN-GJS-500-7
6	Stem	AISI 420	15	Stem Nut	Brass

▲ DIMENSIONS(mm)

Size	L	D	D1	D2	b	n-d	H(open)	W	W.T(kg)
DN40	165	150	110	88	18	4-19	320	180	14.5
DN50	178	165	125	102	20	4-19	347	180	17
DN65	190	185	145	122	20	4-19	390	180	18
DN80	203	200	160	138	22	8-19	470	200	24.8
DN100	229	220	180	158	24	8-19	535	200	34.6
DN125	254	250	210	188	26	8-19	644	250	50.4
DN150	267	285	240	212	26	8-23	739	280	63
DN200	292	340	295	268	30	12-23	936	300	92
DN250	330	405	355	320	32	12-28	1133	360	149
DN300	356	460	410	378	32	12-28	1330	400	197.5
DN350	381	520	470	438	36	16-28	1533	450	261.5
DN400	406	580	525	490	38	16-31	1905	450	441
DN450	432	640	585	548	40	20-31	2072	640	509.3
DN500	457	715	650	610	42	20-34	2302	640	682.5
DN600	508	840	770	725	48	30-37	2650	900	966

Technical Specification

- Design: BS 5150
- Face to Face : BS 5150
- Flanges:EN 1092-2 PN16
- Hydraulic test to ISO 5208
Seat Test Pressure: 17.6 bar
Shell Test Pressure: 24 bar

BS Non-Rising Stem Metal Seat Gate Valve Type B

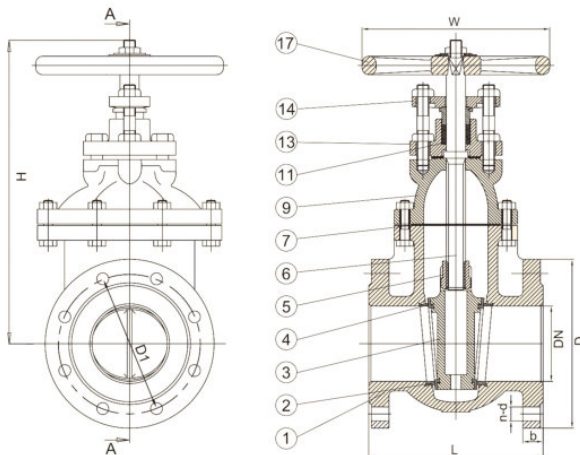

Features

- Bolt bonnet
- Solid wedge
- Graphite packing
- Clockwise closing direction
- Gland flange has two-piece construction
- Seat rings are pressed into wedge and body
- Product color: Blue RAL 5017
- Maximum temperature 178°C

Technical Specification

- Design: BS 5150
- Face to Face : BS 5150
- Flanges: EN 1092-2 PN16
- Hydraulic test to ISO 5208
Seat Test Pressure: 17.6 Bar
Shell Test Pressure: 24 Bar

Optional Extras:

- Position Indicator
- Gear Box
- By-Pass Valve

▲ MATERIAL SPECIFICATION

Item	Part Name	Material	Item	Part Name	Material
1	Body	EN-GJL-250	9	Back Seat	Bronze
2	Seat Ring	Bronze B62/ Brass	12	Packing	Graphite
4	Wedge Ring	Bronze B62/ Brass	14	Gland Follower	EN-GJS-500-7
6	Stem	AISI 420	15	Stem Nut	Brass
7	Bonnet Gasket	Graphite	16	Retaining Nut	EN-GJL-250

▲ DIMENSIONS(mm)

Size	L	D	D1	D2	b	n-d	H	W	W.T(kg)
DN40	165	150	110	84	18	4-19	240	178	18.0
DN50	178	165	125	99	20	4-19	250	178	22.0
DN65	190	185	145	118	20	4-19	265	178	24.1
DN80	203	200	160	132	22	8-19	300	190	29.5
DN100	229	220	180	156	24	8-19	350	250	53.2
DN125	254	250	210	184	26	8-19	410	300	80.0
DN150	267	285	240	211	26	8-23	450	300	95.8
DN200	292	340	295	266	30	12-23	550	356	140.0
DN250	330	405	355	319	32	12-28	650	400	251.0
DN300	356	460	410	370	32	12-28	710	457	365.0
DN350	381	520	470	429	36	16-28	1000	508	450.0
DN400	406	580	525	480	38	16-31	1123	558	696.0
DN450	432	640	585	548	40	20-31	1204	610	950.0
DN500	457	715	650	609	42	20-34	1295	610	1089.0
DN600	508	840	770	720	48	30-37	1478	762	1520.0

BS Rising Stem Solid Wedge Gate Valve Type B

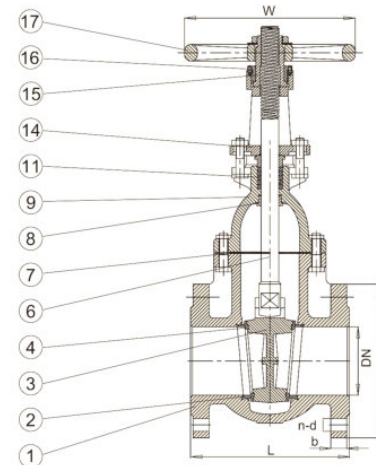
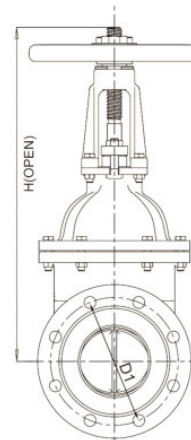

▲ MATERIAL SPECIFICATION

Item	Part Name	Material	Item	Part Name	Material
1	Body	EN-GJL-250	7	Graphite	Graphite
2	Seat Ring	Bronze B62/ Brass	12	Graphite	EN-GJL-250
3	Wedge	EN-GJL-250	13	EN-GJL-250	Graphite
4	Wedge Ring	Bronze B62/ Brass	21	Brass	EN-GJL-250
6	Stem	AISI 420	14	EN-GJS-500-7	EN-GJS-500-7

▲ DIMENSIONS(mm)

Size	L	D	D1	D2	b	n-d	H	W	W.T(kg)
DN40	165	150	110	84	18	4-19	240	178	18
DN50	178	165	125	99	20	4-19	250	178	21.5
DN65	190	185	145	118	20	4-19	265	178	23.5
DN80	203	200	160	132	22	8-19	300	190	28.4
DN100	229	220	180	156	24	8-19	350	250	48.2
DN125	254	250	210	184	26	8-19	410	300	68.0
DN150	267	285	240	211	26	8-23	450	300	81.8
DN200	292	340	295	266	30	12-23	550	356	135.0
DN250	330	405	355	319	32	12-28	650	400	213.2
DN300	356	460	410	370	32	12-28	710	457	313.6
DN350	381	520	470	429	36	16-28	1000	508	400.0
DN400	406	580	525	480	38	16-31	1123	558	610.0
DN450	432	640	585	548	40	20-31	1204	610	800.0
DN500	457	715	650	609	42	20-34	1295	610	980.0
DN600	508	840	770	720	48	30-37	1478	762	1320.0



Features

- Solid wedge
- Back seating design
- Outside screw and yoke
- Stem nut assembled downward
- Gland flange has two-piece construction
- Clockwise closing direction
- Seat rings are pressed into wedge and body
- Product color: Blue RAL 5017
- Maximum temperature 178 °C

Technical Specification

- Design: BS 5150
- Face to Face : BS 5150
- Flanges: EN 1092-2 PN16
- Hydraulic test to ISO 5208
Seat Test Pressure: 17.6 Bar
Shell Test Pressure: 24 Bar

Optional Extras:

- Gear Box
- By-Pass Valve



BS 3464 Non-Rising Stem Metal Seated Gate Valve

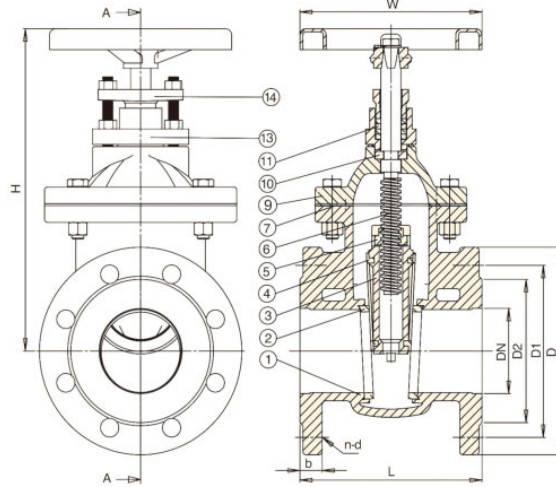

Features

- Bolt bonnet
- Clockwise closing direction
- Solid wedge
- Graphite packing
- Seat rings are pressed into wedge and body
- Product color: Blue RAL 5017
- Maximum temperature 150°C

▲ MATERIAL SPECIFICATION

Item	Part Name	Material	Item	Part Name	Material
1	Body	EN-GJL-250	7	Bonnet Gasket	Graphite
2	Seat Ring	Bronze B62/ Brass	9	Bonnet	EN-GJL-250
3	Wedge	EN-GJL-250	11	Packing	Graphite
4	Wedge Ring	Bronze B62/ Brass	13	Stuffing Box	EN-GJL-250
6	Stem	AISI 420	14	Gland Follower	EN-GJS-500-7

▲ DIMENSIONS(mm)

Size	L	D	Table D		Table E		b	H	W	W.T(kg)
			D1	n-d	D1	n-d				
DN40	140	135	98	4-14	98	4-14	18	240	160	14
DN50	146	150	114	4-18	114	4-18	20	250	160	15
DN65	158.8	165	127	4-18	127	4-18	20	265	160	18.5
DN80	165.1	185	146	4-18	146	4-18	22	300	180	24.9
DN100	171.5	215	178	4-18	178	8-18	24	350	180	34.8
DN125	190.5	255	210	8-18	210	8-18	26	410	200	48
DN150	209.6	280	235	8-18	235	8-22	26	450	250	61.3
DN200	241	337	292	8-18	292	8-22	26	550	280	106
DN250	273	406	356	8-18	356	12-22	28	650	320	138
DN300	305	457	406	8-22	406	12-26	28	710	360	175

BS 3464 Rising Stem Solid Wedge Gate Valve

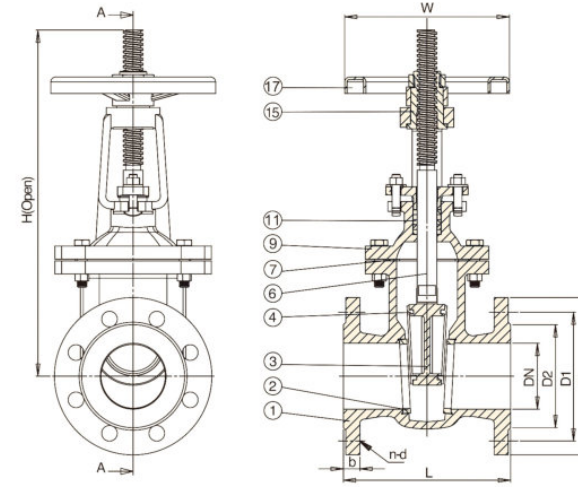

▲ MATERIAL SPECIFICATION

Item	Part Name	Material	Item	Part Name	Material
1	Body	EN-GJL-250	7	Bonnet Gasket	Graphite
2	Seat Ring	Bronze B62/ Brass	9	Bonnet	EN-GJL-250
3	Wedge	EN-GJL-250	11	Packing	Graphite
4	Wedge Ring	Bronze B62/ Brass	14	Gland Follower	EN-GJS-500-7
6	Stem	AISI 420	15	Stem Nut	Brass

▲ DIMENSIONS(mm)

Size	L	D	Table D		Table E		b	H(open)	W	W.T(kg)
			D1	n-d	D1	n-d				
DN40	140	135	98	4-14	98	4-14	18	360	160	15
DN50	146	150	114	4-18	114	4-18	20	375	160	17
DN65	158.8	165	127	4-18	127	4-18	20	405	160	18
DN80	165.1	185	146	4-18	146	4-18	22	415	180	24.8
DN100	171.5	215	178	4-18	178	8-18	24	486	180	34.6
DN125	190.5	255	210	8-18	210	8-18	26	632	200	50.4
DN150	209.6	280	235	8-18	235	8-22	26	710	250	63
DN200	241	337	292	8-18	292	8-22	26	842	280	92
DN250	273	406	356	8-18	356	12-22	28	1100	320	149
DN300	305	457	406	8-22	406	12-26	28	1228	360	197.5

Features

- Bolt bonnet
- Solid wedge
- Outside screw and yoke
- Clockwise closing direction
- Graphite packing
- Seat rings are pressed into wedge and body
- Product color: Blue RAL 5017
- Maximum temperature 150°C

Technical Specification

- Design: BS 3464
- Face To Face : BS 3464
- Flanges:BS 10 Table D/E
- Hydraulic test to ISO 5208
Seat Test Pressure: 17.6 bar
Shell Test Pressure: 24 bar

CAST IRON GLOBE VALVE

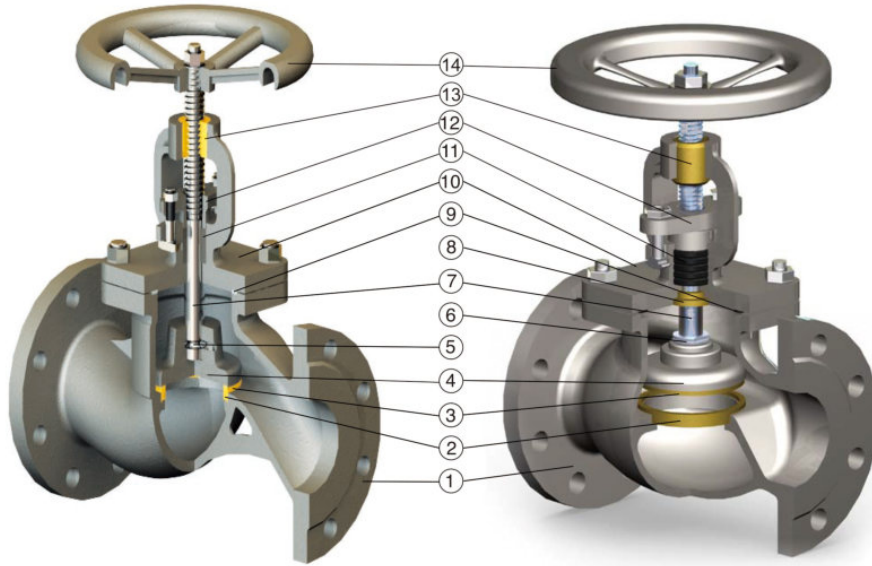

Body
Optimized cavity design, full bore, little flow resistance, good pressurization characteristic.

Seat Ring
Inlaid structure, anticorrosive materials, good sealing property, and long service life.

Disc Ring
Anticorrosive materials, good sealing property, and long time service.

Disc
Ductile Iron material with high strength and impact resistance.

Screw
Bearing steel materials, corrosion proof, long service life.

Ball
Ball connection between disc and stem, turning flexible and sealing credible.

Stem
Stainless steel, corrosion proof, long service life, good mechanical property.

Gasket
Soft graphite, long service life, easy to sealing and maintain.

Nut
High quality carbon steel, better performance.

Stud
High quality carbon steel, better performance.

Packing
Soft graphite, long service life, easy to sealing and maintain.

Gland
High strengthen design, easy to use.

T Bolt
T bolts and nuts, easy to use.

Bonnet
High strengthen design, safe and credible.

Yoke Nut
Brass material, high intensity, small frictional coefficient, corrosion proof and long service life.

Handwheel
High strengthen design, safe and credible.

Washer
High quality carbon steel, better performance.

Nut
High quality carbon steel, better performance.

◆ Application :

As shut-off valves, GLOBE valve are used for Industry, Powerstation, Flue gas purification plant, process technology, gas supply, vapour facilities, thermal oil applications, recycling facilities, vacuum facilities, ammonia, hot water, heating technology, district heating, cooling and freezing systems, general plant manufacturing, steam systems.
Medium : Steam, gas, hot water, thermal fluids, hot oil, process water, vacuum facilities, ammonia etc.

◆ Normal Features:

1. Optimised cavity design, full port, low flow resistance.
2. Outside screw and yoke construction.
3. Stem nut is firmly seated in yoke bonnet head or on antifriction bearings.
4. Deep stuffing box and soft graphite packing can supply safety and long service sealing.

◆ Materials & Specifications

Item No.	Part Name	Specification	Specification	
1	Body	Cast Iron	GG25(EN-GJL-250)	ASTM A126B
		Ductile Iron	GGG50(EN-GJS-500-7)	ASTM A536 65-45-12
2	Seat Ring	Brass	CuZn39Pb3	
		Bronze	EN 1982 CC491K	ASTM B62 C83600
		Stainless Steel		
3	Disc Ring	Brass	CuZn39Pb3	
		Bronze	EN 1982 CC491K	ASTM B62 C83600
		Stainless Steel		
4	Disc	Cast Iron	GG25(EN-GJL-250)	ASTM A126B
		Ductile Iron	GGG50(EN-GJS-500-7)	ASTM A536 65-45-12
		Carbon Steel		A105
5	Ball	Stainless Steel		
6	Disc Nut	Carbon Steel		
7	Stem	Stainless Steel	X20 Cr13	SS AISI 420
		Brass	CuZn39Pb3	ASTM B16 C36000
8	Back Seat	Bronze	EN 1982 CC491K	ASTM B62 C83600
9	Bonnet Gasket	Graphite		
		Graphite With Soft Steel		
10	Bonnet	Cast Iron	GG25(EN-GJL-250)	ASTM A126B
		Ductile Iron	GGG50(EN-GJS-500-7)	ASTM A536 65-45-12
11	Packing	Graphite	Non-asbestos	Non-asbestos
12	Gland Follower	Ductile Iron	GGG50(EN-GJS-500-7)	ASTM A536 65-45-12
13	Stem Nut	Brass	COPPER ALLOY EN 12165	ASTM B16 C36000
14	HandWheel	Ductile Iron	GGG50(EN-GJS-500-7)	ASTM A536 65-45-12

DIN3356 Globe Valve

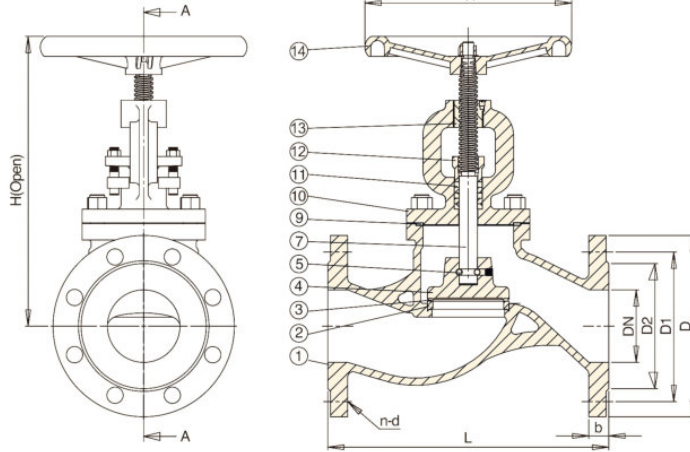

Features

- Bolt bonnet
- Clockwise closing direction
- Graphite packing
- Seat rings are pressed into body
- Product color: Blue RAL 5017

Technical Specification

- Design: DIN 3356
- Face to Face : DIN3202 F1
- Flanges: DIN 2533 PN16
- Hydraulic test to ISO 5208
Seat Test Pressure: 17.6 bar
Shell Test Pressure: 24 bar

▲ MATERIAL SPECIFICATION

Item	Part Name	Material	Item	Part Name	Material
1	Body	GG25	4	Disc	GG25/ Carbon Steel
2	Seat Ring	Stainless Steel	7	Stem	SS AISI 420
		Brass	9	Bonnet Gasket	Graphite With Soft Steel
3	Disc Ring	Stainless Steel	10	Bonnet	GG25
		Brass	11	Packing	Graphite

▲ DIMENTIONS(mm)

Size	L	D	D1	D2	b	n-d	H(open)	W	W.T(kg)
DN15	130	95	65	45	14	4-14	200	120	3.4
DN20	150	105	75	58	16	4-14	220	120	4.7
DN25	160	115	85	68	16	4-14	225	120	5.1
DN32	180	140	100	78	18	4-18	250	120	7.6
DN40	200	150	110	88	18	4-18	270	160	9.5
DN50	230	165	125	102	20	4-18	290	200	13.7
DN65	290	185	145	122	20	4-18	320	200	18.5
DN80	310	200	160	138	22	8-18	365	200	22.1
DN100	350	220	180	158	24	8-18	410	240	34
DN125	400	250	210	188	26	8-18	460	240	47.8
DN150	480	285	240	212	26	8-22	525	280	65.9
DN200	600	340	295	268	30	12-22	685	360	128.8
DN250	730	405	355	320	32	12-26	830	400	196
DN300	850	460	410	378	32	12-26	925	450	245

DIN3356 Angle Globe Valve

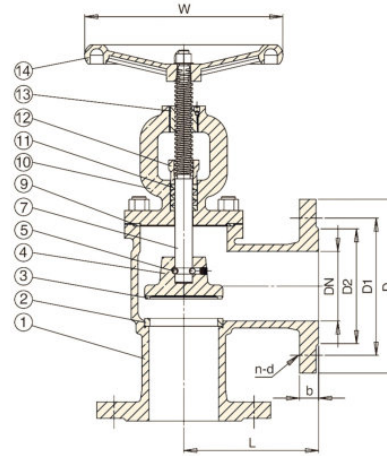

Features

- Bolt bonnet
- Outside acrew and yoke
- Clockwise closing direction
- Graphite packing
- Product color: Blue RAL 5017

Technical Specification

- Design: DIN 3356
- Face to Face : DIN3202 F1
- Flanges: EN 1092-2 PN16
- Hydraulic test to ISO 5208
Seat Test Pressure: 17.6 bar
Shell Test Pressure: 24 bar

▲ MATERIAL SPECIFICATION

Item	Part Name	Material	Item	Part Name	Material
1	Body	GG25	4	Disc	GG25/ Carbon Steel
2	Seat Ring	Stainless Steel	7	Stem	SS AISI 420
		Brass	9	Bonnet Gasket	Graphite With Soft Steel
3	Disc Ring	Stainless Steel	10	Bonnet	GG25
		Brass	11	Packing	Graphite

▲ DIMENTIONS(mm)

Size	L	D	D1	D2	b	n-d	H(open)	W	W.T(kg)
DN15	90	95	65	45	14	4-14	200	120	3.5
DN20	95	105	75	58	16	4-14	220	120	4.2
DN25	100	115	85	68	16	4-14	225	120	5.1
DN32	105	140	100	78	18	4-18	250	120	7.3
DN40	115	150	110	88	18	4-18	270	160	9
DN50	125	165	125	102	20	4-18	290	200	14.6
DN65	145	185	145	122	20	4-18	320	200	19.8
DN80	155	200	160	138	22	8-18	365	200	23.6
DN100	175	220	180	158	24	8-18	410	240	31.4
DN125	200	250	210	188	26	8-18	460	240	46
DN150	225	285	240	212	26	8-22	525	280	58.4
DN200	275	340	295	268	30	12-22	685	360	113.8
DN250	325	405	355	320	32	12-26	830	400	143.6
DN300	375	460	410	378	32	12-26	925	450	176.5

ANSI / MSS SP-85 Globe Valve

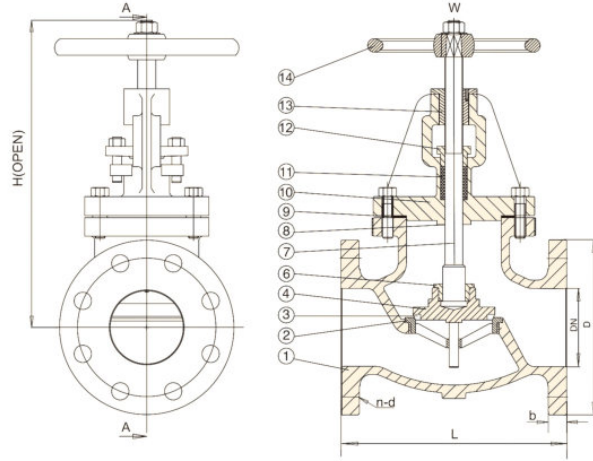

Features

- Bolt bonnet
- Clockwise closing direction
- Graphite packing
- Seat rings are pressed into body
- Product color: Blue RAL 5017
- Maximum temperature 178°C

Technical Specification

- Design: MSS SP-85
- Face to Face : ANSI B16.10
- Flanges:ANSI B16.1
- Hydraulic test to MSS SP-85
Seat Test Pressure: 13.8 bar
Shell Test Pressure: 24.1 bar

▲ MATERIAL SPECIFICATION

Item	Part Name	Material	Item	Part Name	Material
1	Body	ASTM A126B	4	Disc	ASTM A126B/Carbon Steel
2	Seat Ring	ASTM B62 C83600	7	Stem	SS AISI 420
		Stainless Steel	8	Back Seat	CI / ASTM B62
3	Disc Ring	ASTM B62 C83600	9	Bonnet Gasket	Graphite With Soft Steel
		Stainless Steel	11	Packing	Graphite

▲ DIMENTIONS(mm)

Size	L	D	D1	b	n-d	H (open)	W	W.T(KG)
1.5"	165.1	127	98.6	14.2	4 -16	270	160	10
2"	203.2	152	120.7	15.8	4 -19	290	200	12
2.5"	215.9	178	139.7	17.5	4 -19	320	200	16
3"	241.3	191	152.4	19	4 -19	365	200	20
4"	292.1	229	190.5	23.9	8 -19	410	240	31.6
5"	330.2	254	215.9	23.9	8 -22	460	240	40.6
6"	355.6	279	241.3	25.4	8 -22	525	280	50.3
8"	495.3	343	298.5	28.5	8 -22	68.5	360	109.4
10"	622.3	406	362	30.2	12-25	830	400	180
12"	698.5	483	431.8	31.8	12-25	925	450	230

BS5152 Globe Valve

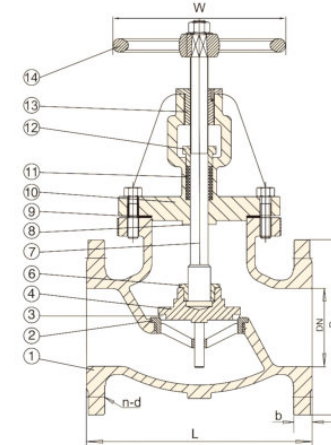
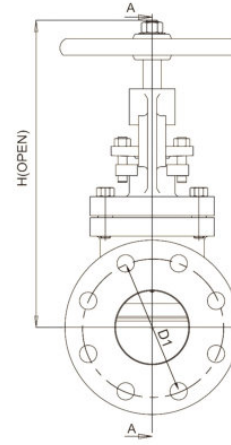

▲ MATERIAL SPECIFICATION

Item	Part Name	Material	Item	Part Name	Material
1	Body	EN-GJL-250	4	Disc	EN-GJL-250/Carbon Steel
2	Seat Ring	ASTM B62 C83600	7	Stem	SS AISI 420
		Stainless Steel	8	Back Seat	CI / ASTM B62
3	Disc Ring	ASTM B62 C83600	9	Bonnet Gasket	Graphite With Soft Steel
		Stainless Steel	11	Packing	Graphite

▲ DIMENTIONS(mm)

Size	L	D	D1	D2	b	n-d	H (open)	W	W.T(KG)
DN40	165	150	110	88	18	4-19	270	160	10
DN50	203	165	125	102	20	4-19	290	200	12
DN65	216	185	145	122	20	4-19	320	200	16
DN80	241	200	160	138	22	8-19	365	200	20
DN100	292	220	180	158	24	8-19	410	240	31.6
DN125	330	250	210	188	26	8-19	460	240	40.6
DN150	356	285	240	212	26	8-23	525	280	50.3
DN200	495	340	295	268	30	12-23	685	360	109.4
DN250	622	405	355	320	32	12-28	830	400	180
DN300	698	460	410	378	32	12-28	925	450	230

Features

- Bolt bonnet
- Clockwise closing direction
- Graphite packing
- Seat rings are pressed into body
- Product color: Blue RAL 5017
- Maximum temperature 200°C

Technical Specification

- Design: BS 5152
- Face to Face : BS 5152
- Flanges:EN 1092-2 PN16
- Hydraulic test to ISO 5208
Seat Test Pressure: 17.6 bar
Shell Test Pressure: 24 bar

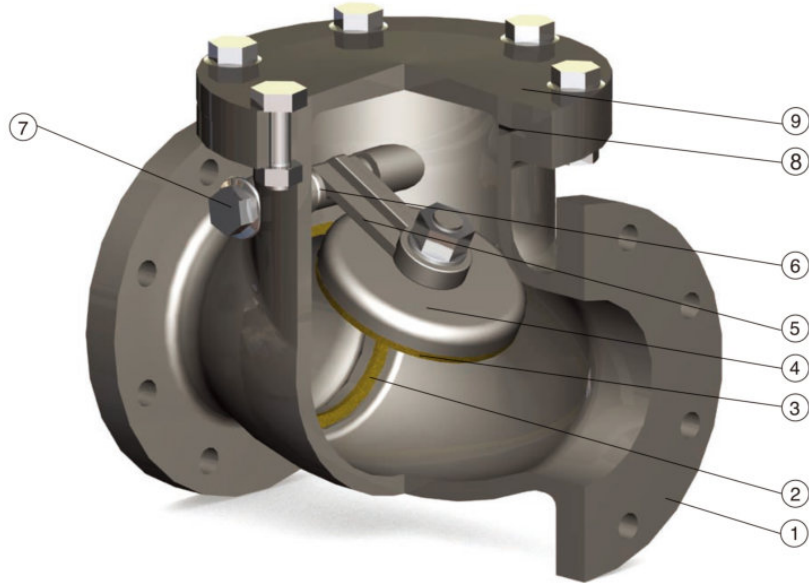

Item No.	Part Name	Material	Specification
1	Body	Cast Iron	GG25(EN-GJL-250) ASTM A126B
		Ductile Iron	GGG50(EN-GJS-500-7) ASTM A536 65-45-12
2	Seat Ring	Brass	CuZn39Pb3
		Bronze	EN 1982 CC491K ASTM B62 C83600
3	Disc Ring	Brass	CuZn39Pb3
		Bronze	EN 1982 CC491K ASTM B62 C83600
		EPDM/NBR	
4	Disc	Cast Iron	GG25(EN-GJL-250) ASTM A126B
		Ductile Iron	GGG50(EN-GJS-500-7) ASTM A536 65-45-12
5	Hanger	Ductile Iron	GGG50(EN-GJS-500-7) ASTM A536 65-45-12
6	Hanger Pin	Stainless Steel	X20 Cr13 SS AISI 420
7	Plug	Zinc Steel	
8	Cover Gasket	Graphite With Soft Steel	
		EPDM/NBR	
9	Cover	Cast Iron	GG25(EN-GJL-250) ASTM A126B
		Ductile Iron	GGG50(EN-GJS-500-7) ASTM A536 65-45-12

DIN 3202 F6 Swing Check Valve

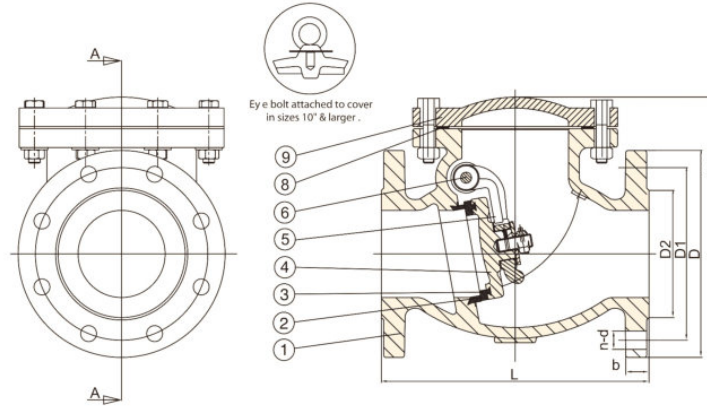

▲ MATERIAL SPECIFICATION

Item	Part Name	Material	Item	Part Name	Material
1	Body	GG25	4	Disc	GG25
2	Seat Ring	Brass	5	Hanger	GGG50
		Bronze	6	Hanger Pin	Stainless Steel
3	Disc Ring	Brass /Bronze	8	Cover Gasket	Graphite With Soft Steel
		EPDM /NBR	9	Cover	GG25

▲ DIMENTIONS(mm)

Size	L	D	D1	D2	b	n-d	H	W.T(kg)
DN40	180	150	110	84	18	4-19	110	9.0
DN50	200	165	125	99	20	4-19	130	13.4
DN65	240	185	145	118	20	4-19	140	17.7
DN80	260	200	160	132	22	8-19	150	20.8
DN100	300	220	180	156	24	8-19	160	29.3
DN125	350	250	210	184	26	8-19	190	47.0
DN150	400	285	240	211	26	8-23	210	67.0
DN200	500	340	295	266	30	12-23	250	118.7
DN250	600	405	355	319	32	12-28	310	171.9
DN300	700	460	410	370	32	12-28	340	232.5
DN350	800	520	470	429	36	16-28	450	330.0
DN400	900	580	525	480	38	16-31	520	460.0
DN450	1000	640	585	548	40	20-31	550	580.0
DN500	1100	715	650	609	42	20-34	590	700.0
DN600	1300	840	770	720	48	20-37	680	780.0

Features

- Full port
- Bolted cover
- Suitable for both horizontal and vertical installation
- Product color: Blue RAL 5017

Options

- External lever arm and weight
- FBE coated inside and outside

Technical Specification

- Face to Face : DIN3202 F6
- Flanges:EN 1092-2 PN16
- Hydraulic test to ISO 5208
Seat Test Pressure: 17.6 bar
Shell Test Pressure: 24 bar

Class 125 Swing Check Valve

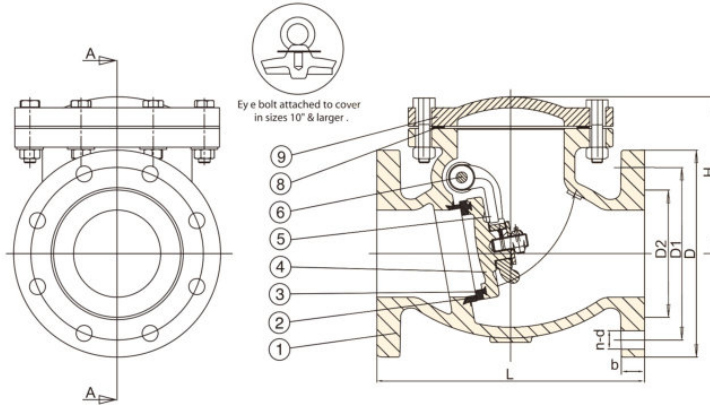

Features

- Full port
- Bolted Cover
- Suitable for both horizontal and vertical installation
- Product color: Blue RAL 5017

Options

- External lever arm and weight
- FBE Coated Inside and outside

Technical Specification

- Design: MSS SP-71
- Face to Face : ANSI B16.10
- Flanges: ANSI B16.1
- Hydraulic test to MSS SP-71
Seat Test Pressure: 220 Psi
Shell Test Pressure: 350 Psi

▲ MATERIAL SPECIFICATION

Item	Part Name	Material	Item	Part Name	Material
1	Body	ASTM A126B	4	Disc	ASTM A126B
2	Seat Ring	Bronze	5	Hanger	ASTM A536 65-45-12
		Brass	6	Hanger Pin	Stainless Steel
3	Disc Ring	Brass /Bronze	8	Cover Gasket	Graphite With Soft Steel
		EPDM /NBR	9	Cover	ASTM A126B

▲ DIMENSIONS(mm)

Size	L	D	D1	b	n-d1	H	W.T(kg)
1 1/2"	165.1	127	98.6	14.2	4-16	110	10.5
2"	203.2	152	120.7	15.8	4-19	130	12.5
2 1/2"	215.9	178	139.7	17.5	4-19	140	17.3
3"	241.3	191	152.4	19	4-19	150	24.5
4"	292.1	229	190.5	23.9	8-19	160	37.5
5"	330.2	254	215.9	23.9	8-22	190	41
6"	355.6	279	241.3	25.4	8-22	210	46.2
8"	495.3	343	298.5	28.5	8-22	250	120
10"	622.3	406	362	30.2	12-25	310	198
12"	698.5	483	431.8	31.8	12-25	340	282
14"	787.4	533	476.3	35	12-29	450	350
16"	914.4	597	539.8	36.6	16-29	520	430
18"	914	635	577.9	39.6	16-32	550	638
20"	1016	699	635	42.9	20-32	590	705
24"	1219	813	749.3	47.8	20-35	680	900

BS 5153 Swing Check Valve

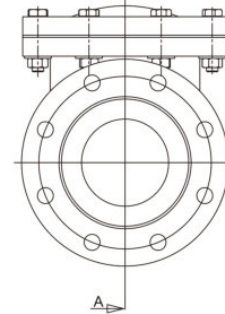

▲ MATERIAL SPECIFICATION

Item	Part Name	Material	Item	Part Name	Material
1	Body	EN-GJL-250	4	Disc	EN-GJL-250
2	Seat Ring	Bronze	5	Hanger	EN-GJS-500-7
		Brass	6	Hanger Pin	Stainless Steel
3	Disc Ring	Brass /Bronze	8	Cover Gasket	Graphite With Soft Steel
		EPDM /NBR	9	Cover	EN-GJL-250

▲ DIMENSIONS(mm)

Size	L	D	D1	D2	b	n-d1	H	W.T(kg)
DN40	165	150	110	88	18	4-19	110	10.5
DN50	203	165	125	102	20	4-19	130	12.5
DN65	216	185	145	122	20	4-19	140	17.3
DN80	241	200	160	138	22	8-19	150	24.5
DN100	292	220	180	158	24	8-19	160	37.5
DN125	330	250	210	188	26	8-19	190	41
DN150	356	285	240	212	26	8-23	210	46.2
DN200	495	340	295	268	30	12-23	250	120
DN250	622	405	355	320	32	12-28	310	198
DN300	699	460	410	378	32	12-28	340	282
DN350	787	520	470	438	36	16-28	450	350
DN400	914	580	525	490	38	16-31	520	430
DN450	914	640	585	548	40	20-31	550	638
DN500	1016	715	650	610	42	20-34	590	705
DN600	1219	840	770	725	48	30-37	680	900

Features

- Full Port
- Bolted Cover
- Suitable for both horizontal and vertical installation
- Product color: Blue RAL 5017

Technical Specification

- Design: BS 5153
- Face to Face : BS 5153
- Flanges: EN 1092-2 PN16
- Hydraulic test to ISO 5208
Seat Test Pressure: 17.6 bar
Shell Test Pressure: 24 bar

Options

- External lever arm and weight
- FBE Coated Inside and outside

BALL CHECK VALVES

▲ APPLICATIONS

Pumping stations for clean, sewage water and loaded or viscous fluids.

▲ TECHNICAL DATA

Range

Threaded ends from DN32 TO DN80.

Flanged ends from DN40-DN300.

Threaded type: BSP acc to ISO 228-1.

Flanged type : EN 1092-2 PN16 and AS4087 (AS2129 Talbe E).

Maximum working pressure 16bars.

Operating temperatures 10°C ~ 80°C.

Seating acc to category A standard ISO 5208.

Minimum backpressure for tightness:0.3bar to 0.5bar.

Face to Face dimensions for flanged type according to EN-558-1 serie 48(DIN3202 F6).



▲ TECHNICAL PEREORMANCES

Full bore ensured.

Self cleaning ball.

Low pressure drop.

Silent.

Removable bonnet for cleaning or changing the ball with out disassembly out of the pipeline.

Horizontal and vertical installation in the pipeline.

▲ TEST

Seat: 1.1x nominal pressure

Body: 1.5x nominal pressure

▲ MOUNTING IN PIPELINE

HORIZONTAL INSTALLATION

VERTICAL INSTALLATION

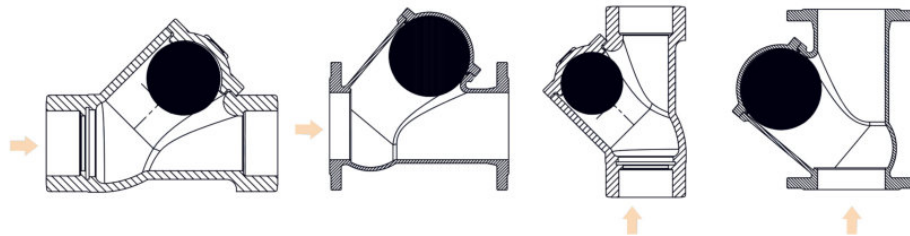

THREADED BALL CHECK VALVE

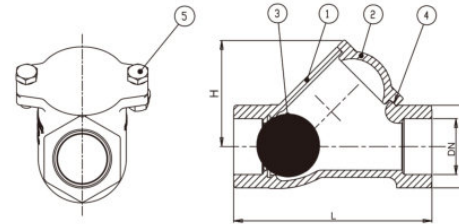

Size	L	B	H	Weight
DN32	135	50	72	2
DN40	145	60	85	2
DN50	175	70	100	3
DN65	200	90	125	5
DN80	248	108	160	7.5

▲ MATERIAL SPECIFICATION

Item NO.	Part Name	Material
1	Body	Ductile Iron
2	Bonnet	Ductile Iron
3	Ball	Steel+NBR
		Steel+EPDM
4	Bonnet GasKet	NBR
		EPDM
5	Bolting	Stainless Steel

FLANGED BALL CHECK VALVE

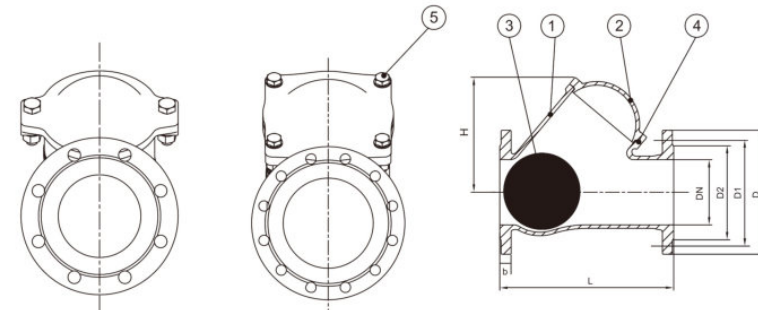

DN40-DN150

DN200-DN300

Size	L	EN 1092-2 PN16				AS 2129 TABLE E				b	H	Weight
		D	D1	D2	n-d	D	D1	D2	n-d			
DN40	180	150	110	84	4-19	150	98	78	4-14	19	90	6.0
DN50	200	165	125	102	4-19	165	114	90	4-18	19	100	6.5
DN65	240	185	145	122	4-19	185	127	103	4-18	19	125	11.0
DN80	260	200	160	138	8-19	200	146	122	4-18	19	136	14.4
DN100	300	220	180	158	8-19	220	178	154	8-18	19	185	20.0
DN125	350	250	210	188	8-19	250	210	186	8-18	19	196	30.4
DN150	400	285	240	212	8-23	285	235	207	8-22	19	265	42.3
DN200	500	340	295	268	12-23	340	292	264	8-22	20	340	73.5
DN250	600	405	355	320	12-27	405	356	328	12-22	22	420	128.0
DN300	700	460	410	378	12-27	460	406	374	12-26	24.5	480	180.0

DIN Lift Check Valve

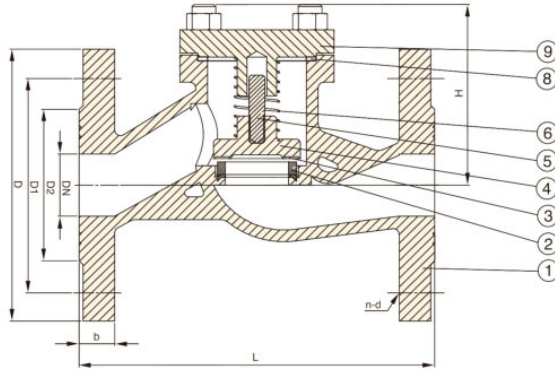

Technical Specification

- Face to Face : DIN3202 F1
- Flanges:EN 1092-2 PN16
- Hydraulic test to ISO 5208
Seat Test Pressure: 17.6 bar
Shell Test Pressure: 24 bar

▲ MATERIAL SPECIFICATION

Item	Part Name	Material	Item	Part Name	Material
1	Body	GG25	4	Disc	GG25/ Carbon Steel
2	Seat Ring	Stainless Steel	5	Stem	SS AISI 420
		Brass	6	Spring	SS AISI 304
3	Disc Ring	Stainless Steel	8	Cover Gasket	Graphite With Soft Steel
		Brass	9	Cover	GG25

▲ DIMENTIONS(mm)

Size	L	D	D1	D2	b	n-d	H
DN15	130	95	65	45	14	4-14	73
DN20	150	105	75	58	16	4-14	83
DN25	160	115	85	68	16	4-14	85
DN32	180	140	100	78	18	4-18	92
DN40	200	150	110	88	18	4-18	97
DN50	230	165	125	102	20	4-18	102
DN65	290	185	145	122	20	4-18	121
DN80	310	200	160	138	22	8-18	149
DN100	350	220	180	158	24	8-18	162
DN125	400	250	210	188	26	8-18	183
DN150	480	285	240	212	26	8-22	214
DN200	600	340	295	268	30	12-22	274
DN250	730	405	355	320	32	12-26	310
DN300	850	460	410	378	32	12-26	357

DIN Rubber Flapper Check Valve

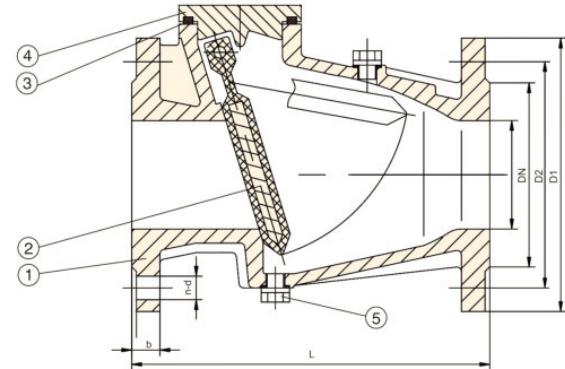

▲ MATERIAL SPECIFICATION

Item	Part Name	Material	Item	Part Name	Material
1	Body	GGG50	5	Plug	Zinc Steel
2	Disc	GGG50+EPDM			
		GGG50+NBR			
3	Cover Gasket	EPDM /BBR			
4	Cover	GGG50			

▲ DIMENTIONS(mm)

Size	L	D	D1	b	n-d	H	W.T(kg)
DN40	180	150	110	84	19	4-19	110
DN50	200	165	125	99	19	4-19	120
DN65	240	185	145	118	19	4-19	135
DN80	260	200	160	132	19	8-19	160
DN100	300	220	180	156	19	8-19	185
DN125	350	250	210	184	19	8-19	205
DN150	400	285	240	211	19	8-23	235
DN200	500	340	295	266	20	12-23	275
DN250	600	405	355	319	22	12-28	320
DN300	700	460	410	370	24.5	12-28	365

Features

- Rubber encapsulated disc
- Drain plug hole makes insertment of lifting equipment for flap possible
- Suitable for both horizontal and vertical installation
- FBE coated inside and outside
- Product color: Blue RAL 5017

Technical Specification

- Face to Face : DIN3202 F6
- Flanges:EN 1092-2 PN16
- Hydraulic test to ISO 5208
Seat Test Pressure: 17.6 bar
Shell Test Pressure: 24 bar

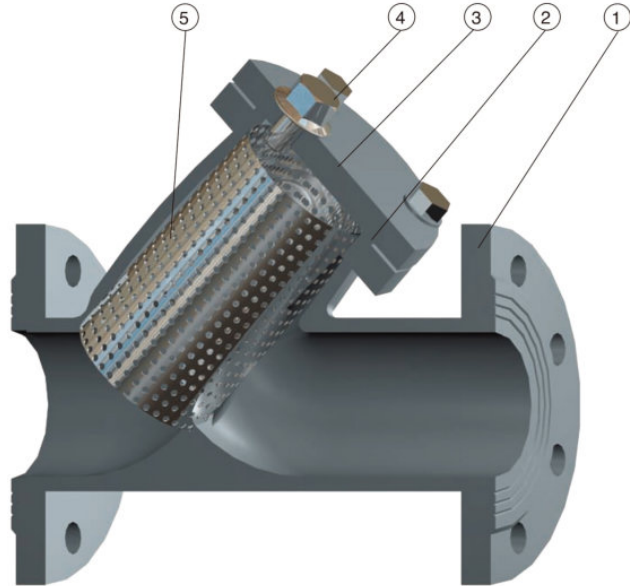

Cover
Cast Iron

Gasket
Graphite Steel Compound Graphite gasket, good performance and long service life.

Body
Cast Iron

Bolt & Nut
galvanized bolt, pretty and incorrosion.

plug
galvanized plug, pretty and incorrosion.

Screen
SS304 Perforated or Mesh screen are all available.

Screen



Woven Wire Type
Woven wire mesh screens are available in both lined and unlined types. Most fine mesh screens require a perforated screen to support a fine wire cloth. This design is very widely used in higher pressures, higher velocity flow and large size Y strainer. Unsupported mesh screens are for lower pressures Service.



Perforated type
Hole sizes range from 0.20" to 1/2" as standard.
Thickness
Standard gauge of screen material ranges from 22 to 11 depending on hole size. Special thicknesses for drilled holes are available. Perforated metal should be not smaller than 1/2 the metal thickness. Perforated screens are easy to clean. Less susceptible to clogging than fine mesh designs.

◆ Screen Options :

An extremely important consideration in the selection of strainer is the size of the perforation or mesh used in the making of the screen. And strainers should provide maximum size of solids that can be passed. The following selection guide charts will help in the selection of the appropriate screen. Screen opening should be approximately 2/3 to 1/2 of maximum allowable solids size. Standard perforated 304 stainless steel are spot welded along the seam for maximum strength. Different size perforations and meshes are available in stainless steel to meet specific media requirements. If the media is not indicated, screens for water will be supplied.

◆ Perforated Sheet Metal Size

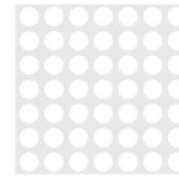

Perf.Hole		Opening	Perf.Hole		Opening
mm	in	%	mm	in	%
1.55	0.062(1/16)	37	1.14	0.045(3/64)	36
3	0.125(1/8)	40	0.80	0.031(1/32)	28

◆ Wire Mesh Size

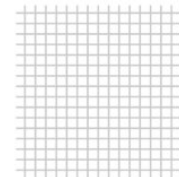

Mesh	Dia.of Wire		Width of Opening		Opening
	mm	mm	mm	%	
21	0.4	0.8	0.8	46	
12	0.87	1.2	1.2	42	
10	1	1.6	1.6	40	

◆ Screen Cleaning

A Y-strainer screen can be cleaned by removing the plug in the bushing, cap or bolted cover allowing the strainer to drain the loose material inside the screen. If a blow-off valve is connected to the strainer it can be opened to achieve the same result as the above. The Y-strainer screen can also be cleaned by removing the bushing, cap or cover to access the screen element. Care should be taken in cleaning screens. After removing a screen, it should be soaked in a cleaning solution or cleaned by using a brush. Do not allow trapped material in the screen to harden, as it will be difficult to remove. A regular cleaning schedule is recommended to avoid screens from becoming clogged.

Y strainer

Y strainer

DIN/BS Y strainer

ANSI Y strainer

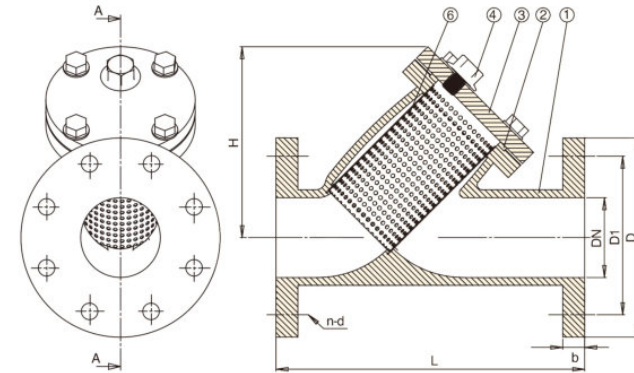
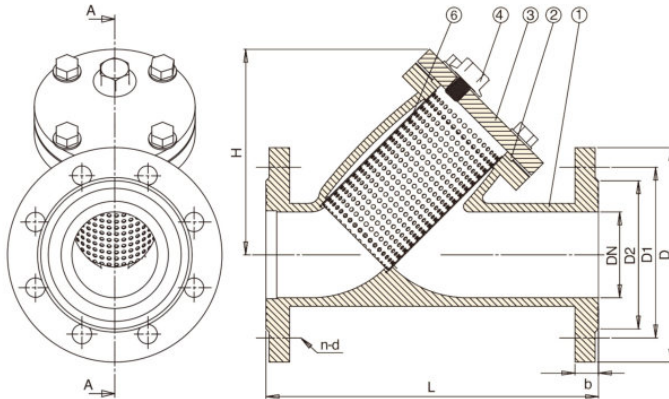

Features

- Y-Pattern
- Stainless Steel Screen
- Bolted Cover
- Flanged Ends
- FBE Coated
- Product color: Blue, RAL 5017

Technical Specification

- Face to Face : DIN3202 F1
- Flanges:EN 1092-2 PN16
- Hydraulic test to ISO 5208
Shell Test Pressure: 24 bar

▲ MATERIAL SPECIFICATION

Item	Part Name	Material	Item	Part Name	Material
1	Body	GG25 /GGG50	5	Bolt&nut	Galvanized flat head bolt
2	Cover Gasket	Graphite With Soft Steel			Galvanized stud bolt
		EPDM/NBR			Stainless Steel
3	Cover	GG25 /GGG50	6	Screen	SS Wire Screen
4	Plug	Zinc Steel BSPT			SS Perforated Mesh

▲ DIMENSIONS(mm)

Size	L	D	D1	D2	b	n-d	H	Plug	W.T(kg)
DN15	130	95	65	46	14	4-14	65	1/4"	2.0
DN20	150	105	75	56	16	4-14	70	1/4"	2.3
DN25	160	115	85	65	16	4-14	80	1/4"	3.2
DN32	180	140	100	76	18	4-19	90	1/4"	5.0
DN40	200	150	110	84	18	4-19	135	1/2"	6.5
DN50	230	165	125	99	20	4-19	150	1/2"	8.7
DN65	290	185	145	118	20	4-19	160	1/2"	12.0
DN80	310	200	160	132	22	8-19	200	1/2"	19.0
DN100	350	220	180	156	24	8-19	240	1/2"	27.0
DN125	400	250	210	184	26	8-19	290	3/4"	40.0
DN150	480	285	240	211	26	8-23	330	3/4"	58.0
DN200	600	340	295	266	30	12-23	380	3/4"	86.0
DN250	730	405	355	319	32	12-28	480	1"	127.0
DN300	850	460	410	370	32	12-28	550	1"	200.0
DN350	980	520	470	429	36	16-28	680	2"	320.0
DN400	1100	580	525	480	38	16-31	780	2"	420.0
DN450	1200	640	585	548	40	20-31	830	2"	620.0
DN500	1250	715	650	609	42	20-34	910	2"	780.0

▲ MATERIAL SPECIFICATION

Item	Part Name	Material	Item	Part Name	Material
1	Body	A126B / A536 65-45-12	5	Bolt&nut	Galvanized flat head bolt
2	Cover Gasket	Graphite With Soft Steel			Galvanized stud bolt
		EPDM/NBR			Stainless Steel
3	Cover	A126B / A536 65-45-12	6	Screen	SS Wire Screen
4	Plug	Zinc Steel NPT			SS Perforated Mesh

▲ DIMENSIONS(mm)

Size	L	D	D1	b	n-d	H	Plug	W.T(kg)
1 1/2"	200.0	127	98.6	14.2	4-16	135	1/2"	6.5
2"	225.4	152	120.7	15.8	4-19	150	1/2"	9.6
2 1/2"	273.0	178	139.7	17.5	4-19	160	1/2"	12.3
3"	292.0	191	152.4	19	4-19	200	1/2"	17.0
4"	352.4	229	190.5	23.9	8-19	240	1/2"	28.1
5"	416.0	254	215.9	23.9	8-22	290	3/4"	40.0
6"	470.0	279	241.3	25.4	8-22	330	3/4"	49.0
8"	543.0	343	298.5	28.5	8-22	380	3/4"	82.3
10"	660.4	406	362	30.2	12-25	480	1"	127.3
12"	762.0	483	431.8	31.8	12-25	550	1"	200.0
14"	946.3	533	476.3	35	12-29	680	2"	320.0
16"	1079.0	597	539.8	36.6	16-29	780	2"	420.0
18"	1168	635	577.9	39.6	16-32	910	2"	620.0
20"	1275	699	635	42.9	20-32	968	2"	780.0
24"	1450	813	749.3	47.8	20-35	1160	2"	1050.0

Features

- Y-Pattern
- Stainless Steel Screen
- Bolted Cover
- Flanged Ends
- FBE Coated
- Product color: Blue, RAL 5017

Technical Specification

- Flanges:ANSI B16.1
- Hydraulic test to API 598
Shell Test Pressure: 350 Psi

AS Y Strainer

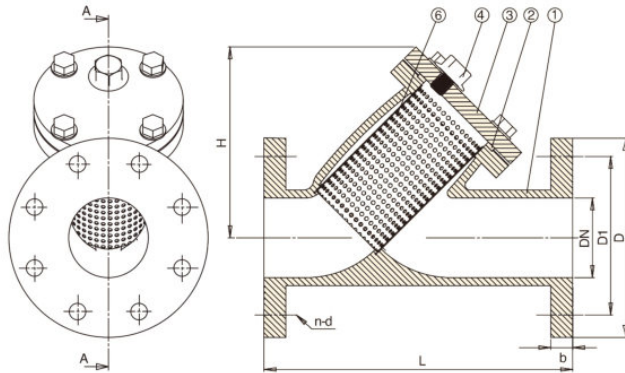

Features

- Y-Pattern
- Stainless Steel Screen
- Bolted Cover
- Flanged Ends
- FBE Coated
- Product color: Blue, RAL 5017

Technical Specification

- Flanges: AS 2129 TABLE E
- Hydraulic test to ISO 5208
Shell Test Pressure: 24 bar

▲ MATERIAL SPECIFICATION

Item	Part Name	Material	Item	Part Name	Material
1	Body	GG25 /GGG50	5	Bolt&nut	Galvanized flat head bolt
2	Cover Gasket	Graphite With Soft Steel			Galvanized stud bolt
		EPDM/NBR			Stainless Steel
3	Cover	GG25 /GGG50	6	Screen	SS Wire Screen
4	Plug	Zinc Steel BSPT			SS Perforated Mesh

▲ DIMENTIONS(mm)

Size	L	D	D1	b	n-d1	H	Plug	W.T(kg)
1 1/2"	200.0	135	98	14.2	4-14	135	1/2"	6.5
2"	225.4	150	114	15.8	4-18	150	1/2"	9.6
2 1/2"	273.0	165	127	17.5	4-18	160	1/2"	12.3
3"	292.0	185	146	19	4-18	200	1/2"	17.0
4"	352.4	215	178	23.9	8-18	240	1/2"	28.1
5"	416.0	255	210	23.9	8-18	290	3/4"	40.0
6"	470.0	280	235	25.4	8-22	330	3/4"	48.9
8"	543.0	335	292	28.5	8-22	380	3/4"	82.3
10"	660.4	405	356	30.2	12-22	480	1"	127.3
12"	762.0	455	406	31.8	12-26	550	1"	200.0
14"	946.3	525	470	35	12-26	680	2"	320.0
16"	1079.0	580	521	36.6	12-26	780	2"	420.0
18"	1168	640	584	39.6	16-26	910	2"	620.0
20"	1275	705	641	42.9	16-26	968	2"	780.0
24"	1450	825	756	47.8	16-33	1160	2"	1050.0

Grooved End Y-Strainer

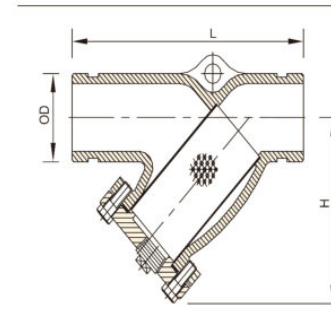

▲ DIMENTIONS(mm)

Size	L	OD	H	Plug
DN50	225	60.3	152	1/2"
DN65	285	73	215	1"
DN65	285	76.1	215	1"
DN80	318	88.9	219	1"
DN100	375	114.3	254	1-1/2"
DN125	448	139.7	322	2"
DN125	448	141.3	322	2"
DN150	502	165.1	365	2"
DN150	502	168.3	365	2"
DN200	640	219.1	462	2"
DN250	710	273	540	2"
DN300	780	323.9	610	2"



• Groove Type: AWWA C606

Simplex Basket Strainers

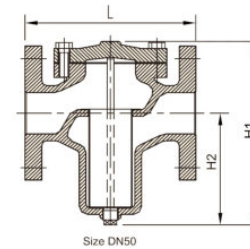

▲ DIMENTIONS(mm)

Size	L	H1	H2	Plug
DN50	207	225	135	1/2"
DN65	210	250	155	3/4"
DN80	251	295	190	3/4"
DN100	292	330	205	1"
DN125	334	370	215	1"
DN150	378	400	235	1"
DN200	475	510	295	1 1/2"
DN250	511	665	340	1 1/2"
DN300	680	760	405	2"
DN350	769	930	585	2"
DN400	842	980	590	2"
DN450	842	1010	590	2"
DN500	842	1110	600	2"
DN600	1054	1690	1175	2"



• Flange Type: EN1092-2 PN16
Other flange types are available

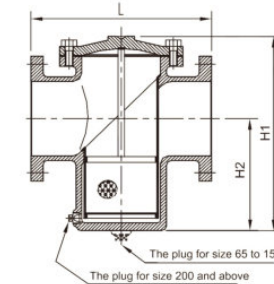



DIN3357 Full Bore Cast Iron Ball Valve

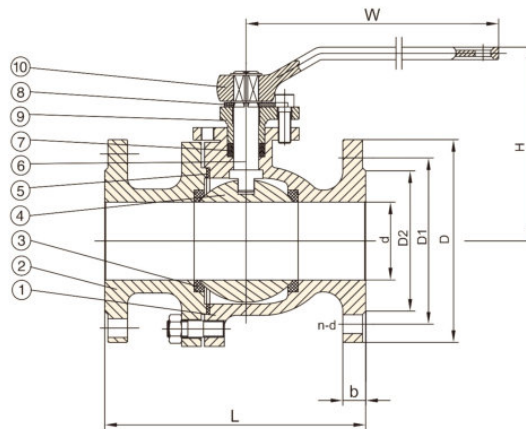

Features

- Full Port
- Low torque operation
- Product color: Blue RAL 5017
- Maximum Temperature 150°C

Options

- ISO Top Flanged
- FBE Coated Inside and outside

Technical Specification

- Design: DIN 3357
- Face to Face :
DN15-DN100 DIN3202 F4
DN125-DN250 DIN3202 F5
- Flanges:EN 1092-2 PN16
- Hydraulic test to ISO 5208
Seat Test Pressure: 17.6 bar
Shell Test Pressure: 24 bar

▲ MATERIAL SPECIFICATION

Item	Part Name	Material	Item	Part Name	Material
1	Body	GG25 / GGG50	6	Stem	SS AISI 410
2	Bonnet	GG25 / GGG50	7	Stem Packing	PTFE
3	Ball	AISI 410 / AISI 304	8	Stop collar	Carbon steel
4	Seat	PTFE / RPTFE	9	Gland flange	GG25 / GGG50
5	Gasket	PTFE	10	Lever	GGG50

▲ DIMENTIONS(mm)

Size	d	L	D	D1	D2	b	n-d	H	W	W.T(kg)
DN15	15	115	95	65	45	14	4-14	78	130	2.6
DN20	20	120	105	75	58	16	4-14	113	160	3.7
DN25	25	125	115	85	68	16	4-14	107	160	4.4
DN32	32	130	140	100	78	18	4-19	113	160	6.6
DN40	40	140	150	110	88	18	4-19	130	250	8
DN50	50	150	165	125	102	20	4-19	146	250	10
DN65	65	170	185	145	122	20	4-19	176	350	15.5
DN80	80	180	200	160	138	22	8-19	222	350	20
DN100	100	190	220	180	158	24	8-19	300	400	26.5
DN125	125	325	250	210	188	26	8-19	325	600	49.5
DN150	150	350	285	240	212	26	8-23	350	600	65.5
DN200	200	400	340	295	268	30	12-23	310	600	142
DN250	250	450	405	355	320	32	12-28	\	\	215

DIN3357 Reduced Bore Cast Iron Ball Valve

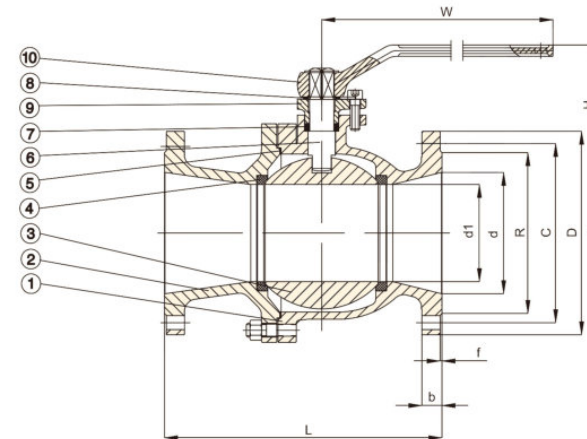

Features

- Reduce Port
- Low torque operation
- Product color: Blue RAL 5017
- Maximum temperature 150°C

Options

- ISO Top Flanged
- FBE Coated Inside and outside

Technical Specification

- Design: DIN 3357
- Face to Face : DIN3202 F4
- Flanges:EN 1092-2 PN16
- Hydraulic test to ISO 5208
Seat Test Pressure: 17.6 bar
Shell Test Pressure: 24 bar

▲ MATERIAL SPECIFICATION

Item	Part Name	Material	Item	Part Name	Material
1	Body	GG25 / GGG50	6	Stem	SS AISI 410
2	Bonnet	GG25 / GGG50	7	Stem Packing	PTFE
3	Ball	AISI 410 / AISI 304	8	Stop collar	Carbon steel
4	Seat	PTFE / RPTFE	9	Gland flange	GG25 / GGG50
5	Gasket	PTFE	10	Lever	GGG50

▲ DIMENTIONS(mm)

Size	d	L	D	D1	D2	b	n-d	H	W	W.T(kg)
DN50	37	150	165	125	102	20	4-19	130	250	9.5
DN65	49	170	185	145	122	20	4-19	145	250	12.5
DN80	58	180	200	160	138	22	8-19	170	350	16.5
DN100	75	190	220	180	158	24	8-19	180	350	20.5
DN125	88	200	250	210	188	26	8-19	205	400	27.5
DN150	98	210	285	240	212	26	8-23	225	400	34.5
DN200	148	230	340	295	268	30	12-23	267	600	74.5
DN200	148	400	340	295	268	30	12-23	267	600	98



MSS/ANSI Full Bore Cast Iron Ball Valve

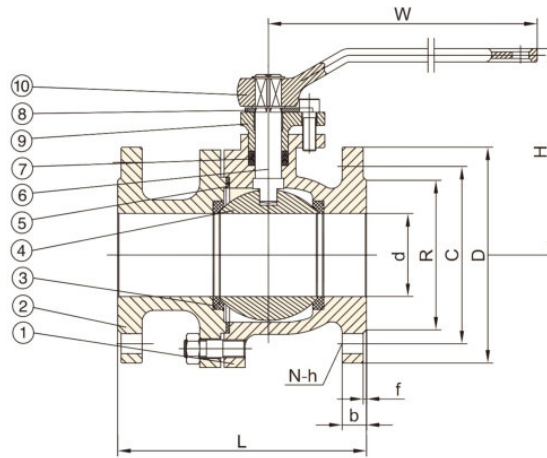

Features

- Full port
- Low torque operation
- Blow-Out Proof Stem
- Stainless steel ball and stem
- Lockable in full open or closed positions
- Product color: Blue RAL 5017
- Maximum temperature 178°C

Technical Specification

- Technical Specification
- Design: MSS SP-72
- Face to Face : ANSI B16.10
- Flanges: ANSI B16.1
- Hydraulic test to API 598
Seat Test Pressure: 220 Psi
Shell Test Pressure: 350 Psi

Options

- ISO Top Flanged
- FBE Coated Inside and outside
- RPTFE-15% Glass Filled Seated

▲ MATERIAL SPECIFICATION

Item	Part Name	Material	Item	Part Name	Material
1	Body	A126B / A536 65-45-12	6	Stem	SS AISI 410
2	Bonnet	A126B / A536 65-45-12	7	Stem Packing	PTFE
3	Ball	AISI 410 / AISI 304	8	Stop collar	Carbon steel
4	Seat	PTFE / RPTFE	9	Gland flange	A126B / A536 65-45-12
5	Gasket	PTFE	10	Lever	A536 65-45-12

▲ DIMENTIONS(mm)

Size	d	L	D	D1	D2	b	n-d1	H	W	W.T(kg)
1/2"	15	108	89	60.5	35	9.7	4-16	78	130	2.5
3/4"	20	117	98.6	70	43	10.5	4-16	113	160	3.2
1"	25	127	108	79.5	51	11.2	4-16	107	160	3.9
1 1/4"	32	140	117	89	63.5	12.7	4-16	113	160	5.1
1 1/2"	40	165	127	98.5	73.5	14.2	4-16	130	250	8
2"	50	178	152	120.5	92	15.9	4-19	146	250	10
2 1/2"	65	191	178	139.5	104.7	17.5	4-19	176	350	15
3"	80	203	191	152.5	127	19.1	4-19	222	350	19
4"	100	229	229	190.5	157.2	23.9	8-19	222	400	28.5
5"	125	254	254	216	186	24	8-22	250	600	49.5
6"	150	267	279	241.5	216	25.4	8-22	275	600	66.5
8"	200	292	343	298.5	270	28.5	8-22	310	600	102
10"	250	330	406	362	332	30.2	12-25	345	600	190

Single Sphere Rubber Expansion Joint

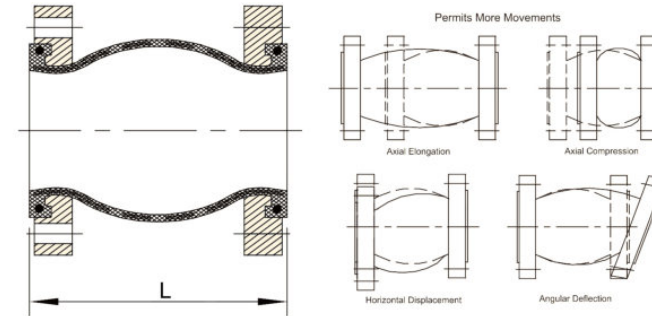

▲ MATERIAL SPECIFICATION

Item	Part Name	Material
1	Flanges	Carbon Steel - Zinc Plated
2	Reinforcing Wire	Carbon Steel Wire Strand
3	Tube	Synthetic Rubber
4	Cover	Synthetic Rubber
5	Reinforcing Cord	Synthetic Fiber

▲ DIMENTIONS(mm)

Size	L	Axial Elongation	Axial Compression	Horizontal Displacement	Angular Deflection
DN32	95	6	9	9	15°
DN40	95	6	10	9	15°
DN50	105	7	10	10	15°
DN65	115	7	13	11	15°
DN80	135	8	15	12	15°
DN100	150	10	19	13	15°
DN125	165	12	19	14	15°
DN150	180	12	20	22	15°
DN200	210	16	25	22	15°
DN250	230	16	25	22	15°
DN300	245	16	25	22	15°
DN350	255	16	25	22	15°
DN400	255	16	25	22	15°
DN450	255	16	25	22	15°
DN500	255	16	25	22	15°
DN600	260	16	25	22	15°
DN700	260	16	25	22	15°
DN800	260	16	25	22	15°
DN900	260	16	25	22	15°
DN1000	260	16	25	22	15°

Features

- Easy installation and remove.
- Absorbs water vibration, noise and shock
- Higher resistance to deformation under pressure
- Widely applicable fluids and areas
- Flange Type: EN1092 PN10/16
Other flange types are available

Double Sphere Rubber Expansion Joint

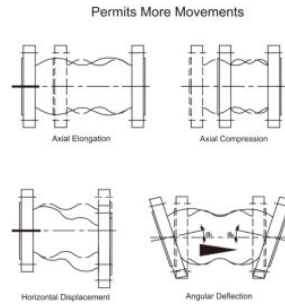
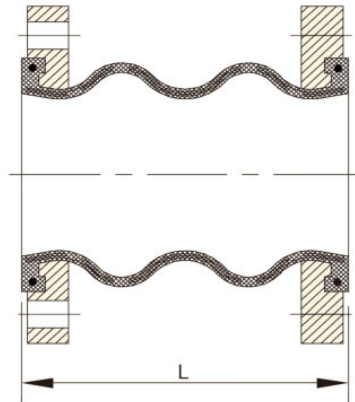

Features

- Easy installation and remove.
- Absorbs water vibration, noise and shock
- Higher resistance to deformation under pressure
- Widely applicable fluids and areas
- Flange Type: EN1092 PN10/16
Other flange types are available

▲ MATERIAL SPECIFICATION

Item	Part Name	Material
1	Flanges	Carbon Steel - Zinc Plated
2	Reinforcing Wire	Carbon Steel Wire Strand
3	Tube	Synthetic Rubber
4	Cover	Synthetic Rubber
5	Reinforcing Cord	Synthetic Fiber

▲ DIMENSIONS(mm)

Size	L	Axial Elongation	Axial Compression	Horizontal Displacement	Angular Deflection
DN32	165	20	50	45	30°
DN40	175	20	50	45	30°
DN50	175	20	50	45	30°
DN65	175	20	50	45	30°
DN80	175	20	50	40	30°
DN100	225	30	50	40	30°
DN125	230	30	50	40	30°
DN150	325	30	50	40	30°
DN200	325	35	50	40	30°
DN250	325	35	60	35	30°
DN300	325	35	60	35	30°
DN350	350	20	40	30	30°
DN400	350	20	40	30	30°
DN450	350	20	40	30	30°
DN500	350	25	40	30	30°
DN600	350	25	40	30	30°

Double Sphere Union Type Rubber Expansion Joint

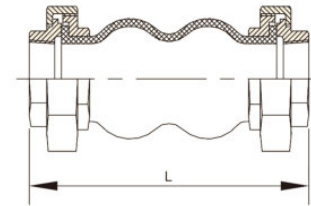

▲ DIMENSIONS(mm)

in	Size	L	Axial Elongation	Axial Compression	Lateral Movement	Angular Flexion
1/2"	DN15	180	5-6	22	22	45
3/4"	DN20	180	5-6	22	22	45
1"	DN25	180	5-6	22	22	45
1 1/4"	DN32	200	5-6	22	22	45
1 1/2"	DN40	210	5-6	22	22	45
2"	DN50	220	5-6	22	22	45
2 1/2"	DN65	245	5-6	22	22	45
3"	DN80	245	5-6	22	22	45



- Working pressure PN16
- Thread type: BSP or NPT

Rubber Expansion Joint

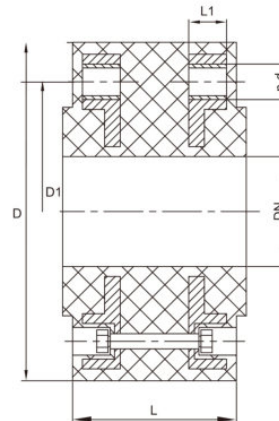

▲ DIMENSIONS(mm)

Size	L	D	D1	n-M	L1	W.T(kg)
DN20	70	105	75	4-M12	12	2
DN25	70	115	85	4-M12	16	2.7
DN32	70	140	100	4-M16	16	4.1
DN40	70	150	110	4-M16	16	4.4
DN50	70	165	125	4-M16	16	5.1
DN65	70	185	145	4-M16	16	6.2
DN80	70	200	160	8-M16	18	7.5
DN100	70	220	180	8-M16	18	8.1
DN125	70	250	210	8-M16	18	9.4
DN150	70	285	240	8-M20	18	12.4
DN200	90	340	295	8-M20	20	18.8



- Working pressure PN10
- Flange type: EN 1092-2 PN10